

User's Manual

PPC-106T

10.4" TFT Low Power 667Mhz Panel PC

Pictures of PPC-106T



Silver (Stainless Steel Color)



VESA-75

VESA-100



I/O ports

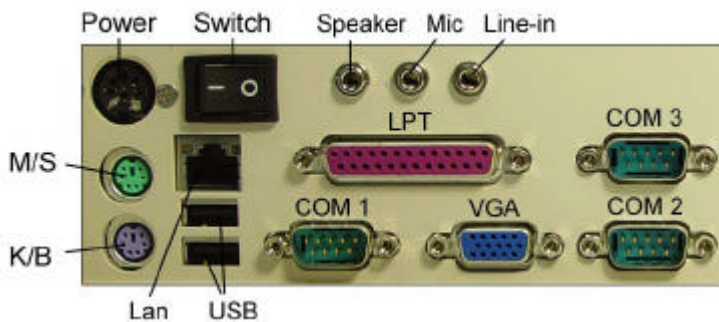

Panel PC Specifications

Display - 10.4" color TFT flat panel

Display Type - TFT LCD panel

Luminance - 150 cd/m2 brightness luminance

CPU - P-III equivalent Low power 640-480Mhz CPU L1 & L2 cache built on CPU

System Chipset - Twister-T , VIA VT8606 , 82C686B

Front Bezel - Thick 10mm Aluminum-alloy hairline anodizing treatment front bezel

Housing & Wall-mounting - Rugged 1.2mm thick steel metal with white painting VESA-75 and VESA-100 compliant

Surface Treatment of Front Panel - Super high-end hairline anodizing treatment, color

Standard Colors - Stainless Steel silver color

Front Panel Protection - Meet NEMA 4, 12 and IP65, 56 water resistant EIA standard

System Memory - 128 MB PC133 SDRAM on board

CD-ROM - One slim size CD-ROM, 24x speed built in

HDD (optional) - 10 - 20GB slim size HDD

Disk On Module (optional) - Support DOM up to 512MB

Disk On Chip (optional) - Support M-System's DOC up to 288MB

Serial ports - 4x COMs (3 x RS232 port , 1 x RS232/422/485 port, 1 for Touch Controller)

USB - 2 x USB ports and IrDA pin header on board

Parallel Port - LPT port for Printer connection

Keyboard and Mouse - One PS/2 KB/Mouse port

Audio I/O - Microphone, Speaker, Line-in

Network Interface Controller Chipset - Realtek 8139C ,support 10/100 Mbp, auto-negotiation, auto-switch LAN

VGA - Display Controller Chipset - S3 Savage 4 ,support AGP 4X LCD/ 2-channel LVDS, TFT, DSTN LCD/CRT with 32MB share Video memory, 3D/2D support

. Power Supply



Input : 100-240VAC ~ 2A 50/60Hz

DC Output : +5V/7A, +12V/1.5A

-12V/0.3A, +5Vsb/0.75A

. NAGASAKI Panel PC Comparison table

Model no.	SBC	CPU	Power
PPC-64T	NASA-6820	667Mhz on board	AC-DC Adaptor
PPC-70T	MS-2100	300Mhz on board	AC-DC Adaptor
PPC-106T	NASA-6109	667Mhz on board	AC-DC Adaptor
PPC-106T-DC	NASA-6109	667Mhz on board	DC-DC Adaptor
PPC-107PT	NASA-6109	667Mhz on board	AC-DC Adaptor
PPC-107PT-DC	NASA-6109	667Mhz on board	DC-DC Power
PPC-127T	NASA-6109	667Mhz on board	AC-DC Adaptor
PPC-127T-DC	NASA-6109	667Mhz on board	DC-DC Adaptor
PPC-128HT	NASA-6104LL	800Mhz	AC-DC Adaptor
PPC-129PT	NASA-6109	667Mhz on board	AC-DC Adaptor
PPC-129PT-DC	NASA-6109	667Mhz on board	DC-DC Adaptor
PPC-156T	NASA-6102	667Mhz on board	AC-DC Power
PPC-157T	NASA-6109	667Mhz on board	AC-DC Adaptor
PPC-157T-DC	NASA-6109	667Mhz on board	DC-DC Adaptor
PPC-158T	NASA-6111	667Mhz on board	AC-DC Power
PPC-159T	NASA-6101	667Mhz on board	AC-DC Power

. Touch Panel

1. Application

2. Warranty

3. Features

4. Characteristics

4.1 Usable Temperature Range

4.2 Storage Temperature Range

4.3 Input Method

5. Electrical Specifications

5.1 Linearity

5.2 Insulation Resistance

5.3 Chattering Time

6. Mechanical Specifications

6.1 Operating Force (with pen)

6.2 Surface Hardness

7. Optical Specifications

7.1 Light Transmittance

8. Reliability

8.1 Line drawing operation

8.2 Pen hitting operation

9. Environment Durability Performance

9.1 High Temperature Test

9.2 Low Temperature Test

9.3 Humidity Test

9.4 Thermal Shock Test

9.5 Resistance to Chemical

10. Quality Level

10.1 Inspection condition

10.2 Criterion

10.3 Glass Fragment

10.4 Newton ring

11. Cautions

1. Application : This specification is applied to 6wire Touch Panel.

2. Warranty : TOUCH PANEL products manufactured to this specification shall be capable of meeting all characteristics for a minimum period of 12 months the date of shipping from NAGASAKI IPC when stored or used as specified under normal conditions within the contents of these sheets. If TOUCH PANEL products are not stored or used as specified herein, it will be void the 12 months warranty.

3. Features

Type : Analog Resistive Type Touch Panel

Input Mode : Polyester Pen or Finger

Structure : Film—ITO Film Glass—ITO Glass

4. Characteristics

4.1 Operating Temperature Range : From -20 to 60 (Humidity 90%RH or lower, no dew condition shall be acceptable)

4.2 Storage Temperature Range : From -30 to 70
(Humidity 90%RH or lower, no dew condition shall be acceptable)

4.3 Input Method :

(1) with Polyester Pen :

Operation and measurement with a pen must be carried out under the following trip condition :

Material : Polyester Tip : SR 0.8 millimeter

(2) with Finger :

Operation and measurement with a finger must be carried out under the

Material : Silicon rubber (Hardness: 60° Hs) Tip : SR 12.5 millimeter

5. Electrical Specifications

5.1 Linearity Direction : $\pm 1.5\%$ or less (with calibration controller)

5.2 Insulation Resistance : 20 MO or more @ DC 25V

5.3 Chattering Time : 10 millisecond or less @ 100KO

6. Mechanical Specifications **Item No.** Item Ratings Test Methods & Condition

6-1 Operating Force (with Polyester Pen SR 0.8)

According to applicable product specification Less than 150g Using a load cell with a Polyester Pen conforming to the specifications set forth in item 4.3 (1) attached to its tip, apply a vertical load within the valid area.

Using the measurement circuit illustrated in diagram 6-1 below, take the gauge value when the voltage value 4.5V or greater as the pressure load value.

6-2 Surface Hardness : 2H or Higher JIS-K5400

7. Optical Specifications

7.1 Light Transmittance (Total Transmittance) : More than 78% (Measuring apparatus : Haze meter-made by BYK-Gardner

Type : Haze-Gard-plus 4726 Illuminant : CIE-A Standard : ASTM D 1003)

8. Reliability Item No. Item Ratings Test Methods & Condition

8-1 Line drawing operation 1,000,000 times of drawing Requirement in paragraph 5 and 6 Drawing must occur in following manner at any point within an Action area.

- 1) Testing equipment : Pen plotter
- 2) Testing load / force : 2.5 N
- 3) Sliding speed : 200 mm / second
- 4) Tip probe : Polyester Pen as defined in sub-paragraph 4-3 (1)

8-2 Pen hitting operation 5,000,000 hits with a pen Requirement in paragraph 5 and 6 Hits must be made in the following manner at any point within at effective area.

- 1) Testing equipment : Pen plotter
- 2) Testing load : 2.5 N
- 3) Press speed : 3 hits / second
- 4) Tip probe : Polyester Pen as defined in sub-paragraph 4-3 (1)

9. Environment Durability Performance Item No. Item Ratings Test Methods & Condition

9-1 High Temperature Test Requirement in paragraph 5 and 6 Put it in a vessel at the condition of 70 ± 1 and $45 \pm 1\%$ humidity relative for 120 hours. Moreover let it alone for 24 hours or more in a room temperature and measure it.

9-2 Low Temperature Test Requirement in paragraph 5 and 6 Put it in a vessel at the condition of -30 ± 1 for 120 hours. Moreover, let it alone for 24 hours or more in a room temperature and measure it.

9-3 Humidity Test Requirement in paragraph 5 and 6 Leave in an environment of 60 ± 1 and $90 \pm 1\%$ relative humidity for 120 hours and then perform measurements after leaving at room temperature for 24 hours

9-4 Thermal Shock Test Requirement in paragraph 5 and 6 Put it in a vessel at the condition of 70 ± 1 for 30 minutes and then -30 ± 1 for 30minutes and his process is repeated by 10cycles. Moreover let it alone for 24 hours in a room temperature and measure it.

9-5 Resistance to chemicals (Surface hard coating) No abnormality in external appearance Lightly wipe the surface with methyl alcohol, artificial perspiration or household cleanser (neutral).

10. Quality Level

10.1 Inspection Condition The inspection shall be performed by using Back light $150-300 \text{ cd/m}^2$, $1000-1400 \text{ Lux}$ (natural light) under the surface of sensor. The panel shall be position sensors from 45cm form eyes and an. Angle 30 degree (15-45), 15 second viewing time.

10.2 Criterion The followings are applied to viewing area The item 10.2 (1,2,3,4) should apply to the VA (view area) unless none VA affect electrical performance

(1) Scratch

Width 0.1mm and length 20mm : Accept .

Width > 10 mm or Length > 20mm : Reject

(2) Granular foreign object

Diameter 0.5mm : Acceptable 0.5mm < Diameter : Unacceptable

(3) Linear foreign object (fiber)

Width 0.05 and Length 5mm : Accept Width 0.05 and Length > 5mm : Unacceptable

(4) Blistering (Puffiness, Baggy) Check through any 0.5millimeter gauge whether a Touch Panel surface film does not contact a measuring face.0.5mm gauge 0.5mm Tablet

10.3 Glass Fragment

(1) Corner Fragment a 2mm ; b 2mm and(c: break height t) : It is acceptable two (t : Glass Thickness)

(2) Side Fragment a 3mm , b 2.0mm and c 1/2t : acceptable

five and interval of faults is 20mm minimum every side. (t : Glass Thickness)

10.4 Newton ring

Diameter 35mm , Acceptable

Pass if defect that fails size cannot be seen when held in front of colors program on monitor.

11.Cautions Item No. Subject Note

11.1 Storage 1) Store Touch Panel at the stated temperature and humidity range.

2) Store Touch Panel with original packing.

3) Do not expose Touch Panel directly to the sun

11.2 Unpacking 1) Do not hold FPC / Copper tail to take Touch Panel out of the package.

2) Open the package after checking "UP / DOWN" mark.

3) Do not put the heavy shock and stress on Touch Panel.

11.3 Handling 1) Wear gloves at handling to prevent stains on Touch Panel or injury by the sharp edge of touch glass.

2) Do not hold FPC / Copper while handling Touch Panel.

3) Do not pile Touch Panels and put heavy matter on Touch Panel.

4) Do not add any stress on touch film.

5) Use dry cloth or soft cloth with alcohol, neutral detergent or one with ethanol at cleaning in case of dirt.

6) Do not use organic solvents except alcohol. 11.4 Assembling 1) Avoid excessive force on the Touch Panel.

7) Do not give unnecessary strain to the FPC / Copper tail while assembling.

Copyright Notice

The content of this manual has been checked for accuracy. The manufacturer assumes no responsibility for any inaccuracies that may be contained in this manual. The manufacturer reserves the right to make improvements or modification to the this document and/or the product at any time without prior notice. No part of this document may be reproduced, transmitted, photocopied or translated into any language, in any form or by any means, electronic, mechanical, magnetic, optical or chemical, without the prior written permission of the manufacturer. VIA is registered trademark of VIA Technology Incorporation VT82C686A may only be used to identify products of VIA Technology Realtek is registered trademark of Realtek Technologies Inc. Multiscan is a trademark of Sony Corp of America IBM, EGA, VGA, PC/XT, PC/AT, OS/2 and PS/2 are registered trademarks of International Business Machines Corporation Intel is a registered trademark of Intel Corporation Plug and Play is registered trademarks of Intel Corporation Microsoft, Windows and MS-DOS are trademarks of Microsoft Corporation Award is a trademark of Award Software Inc. PCI is a registered trademark of PCI Special Interest Group Other product names mentioned herein are used for identification purpose only and may be trademarks and/or registered trademarks of their respective companies.

Installation Notice

The manufacturer recommends using a grounded plug to ensure proper motherboard operation. Care should be used in proper conjunction with a grounded power receptacle to avoid possible electrical shock. All integrated circuits on this motherboard are sensitive to static electricity. To avoid damaging components from electrostatic discharge, please do not remove the board from the anti-static packing before discharging any static electricity to your body, by wearing a wrist-grounding strap. The manufacturer is not responsible for any damage to the motherboard due to improper operation.

Specification

This manual covers two different layout models, and the respective board layouts are shown in chapter 1-4. Please refer to the following description to make sure which model on hand before using.

MODEL	NASA-6109
System Chipset	VIA PM133 , VT8601/VT686B

CPU Supporting	Embedded VIA EDEN ESP5000 (533MHz) or VIA c3 800MHz CPU
LAN Adapter	Realtek 8139C or Intel 82559ER
Audio Adapter	*Optional
VGA Adapter	On chip 2D/3D Graphic Controller w/ SMA up to 8MB
LCD Supporting	TFT TTL LCD optional LVDS I
ROM-Disk Socket	Yes (2-288MB)
TV-Out	Optional
I/O Port	4S/2P
IDE Interface	U. DMA 33/66/100
DIMM Socket	1
Max. RAM Size	512MB
VGA Memory Size	8MB
Watch Dog Timer	Optional
AT/ATX Power	Yes
USB Feature	Yes
Board SizeFormat	203 x 146mm SBC Format

Chapter 1. Introduction

In order to cope with the challenges of the heating issues and demand of much more diminutive embedded system in diverse application, NASA-6109 series CPU boards provides the ultimate solution by integrating with VIA's technology low power consumption VIA C3 series CPU and VIA EDEN fanless ESP series CPU. NASA-6109 series CPU boards offer the assorted functions for various applications such as high-end POS systems, kiosks, networking systems, controlling terminals and other embedded systems.

NASA-6109 is a 5.25" SBC uses VIA chipsets built-in VGA and Audio feature onboard, support TFT TTL LCD feature with LVDS interface as feature option; built-in Realtek 8139XX LAN chipset with RJ45 Jack for 10BaseT/ 100BaseT. The option of Intel 82559ER chip is also provided for the LAN support. This SBC offers the highest performance PC specification in the industry with embedded low power consumption VIA EDEN fanless ESP series CPU ESP5000, and

with the option of the higher performed VIA C3 800MHz CPU. For easier assembly and better integration without arranging array of cables, NASA-6109 provides onboard connectors with a similar conventional ATX layout.

NASA-6109 provides the option of integrating Watch Dog Timer for ideal unattended terminals. To offer better flexibility, it also provides the options of riser card for PCI or ISA expansion through a 188-pin slot. This CPU board is fully compatible with industry standards, adding many technical enhancements and are fully compatible with thousand of software application such as WIN 95, 98, WIN NT 3.x/ 4.x, WIN 2000, WIN ME, WIN CE (.NET), LINUX, UNIX, Novell...etc. The control logic provides high-speed performance for the most advanced multi-user, multitasking application available today. "Tomorrow's PC technology is here today".

1-1. Features

NASA-6109, embedded VIA C3 TM, Eden TM, Ezra TM Low Power EPGA processors.

133 / 100 / 66 MHz CPU Front Side Bus (FSB)

DRAM interface synchronous or pseudo synchronous with CPU FSB speed of 133 / 100 / 66 MHz Mixed 1M / 2M / 4M / 8M / 16M / 32MxN DRAMs

1 or 2 DIMM 168 Pin socket supported up to 512MB or 1.0GB

3.3V DRAM interface with 5V-tolerant inputs

Support Dual channel UltraDMA-100 / 66 / 33 enhance IDE

AC-97 link.

On-board built-in 2 or 4 USB ports.

Integrated Super-I/O support 4 Serial with power selector and 2 parallel ports.

Optional RS-422/485 via COM2

System Hardware monitoring

Keyboard / mouse interfaces.

RTC / CMOS

PCI-2.2 compliant, 32 bit 3.3V PCI interface with 5V tolerant inputs.

33 MHz operation on the primary PCI bus

188pin expansion slot for both PCI and ISA Bus signals.

PC99 Hardware Support

Watch-Dog-Timer support 1-255sec programmable.

On-board support Realtek or Intel 82559/ER 10/100 LAN adapter with RJ-45 port.

AGP v1.0 compliant

Integrated AGP Bus 2D / 3D graphic accelerator.

Windows 95 OSR-2 VXD and integrated Windows 98 / NT5 miniport driver support

BIOS shadow at 16KB increment

Supports 2, 4 and 8 Mbytes of Frame Buffer with share memory.

DirectDraw™ and DirectVideo™ Hardware Support

Advanced Mobile Power Management

CRT Power Management (VESA™ DPMS)

Optional for Flat Panel Interface (TTL or LVDS)

The board is designed to support industry standard TFT panel via 44pin connector or LVDS transmitters. The interface supports both 18-bit and 24-bit display modes. Optionally, an 18+18 panel can be supported utilizing external latches.

Optional Features

Supports RS422/RS485 interface with COM2

Support LVDS LCD panel

Supports Audio function (via AV Card Kit)

Supports TV-Out feature (via TV-Out adapter Kit)

Support Watch Dog Timer / POST code (WDT only for NASA-6109)

Support BOOT ROM

Ordering information

NASA-6109

1. NASA-6109VLA: Support 1 LAN
2. NASA-6109LVDS: Support 1 LAN + LVDS

Note: The standard version of NASA-6109 is embedded with VIA EDEN Fanless 533Mhz and 667MHz.

Other option CPUs will be provided upon request.

1-2. Unpacking

The motherboard comes securely packaged in a sturdy cardboard shipping carton. In addition to the User's Manual, the motherboard package includes the following items:

NASA-6109 5.25" SBC / CPU Board

HDD/FDD Cables

TV-Out adapter / cable (Optional)

Audio Kit (Optional)

LCD cable (Optional)

IDE Driver includes: Drivers for Windows NT 3.x / 4.x, Windows 95, 98, 2000, Win Me, Linux, Novell Netware and AMI FLASH ROM utilities.

Driver utilities for on-board VGA drivers, LAN adapter and DOC 2000

If any of these items are missing or damage, please contact the dealer from whom you purchase the motherboard.

Save the shipping material and carton in the event that you want to ship or store the board in the future.

Note: Leave the motherboard in its original package until you are ready to install it !

1-3. Electrostatic Discharge Precautions

Make sure you properly ground yourself before handling the motherboard, or other system components. Electrostatic discharge can easily damage the components.

Note: You must take special precaution when handling the motherboard in dry or air-conditioned environments

1-4. 5.25" SBC (NASA-6109)

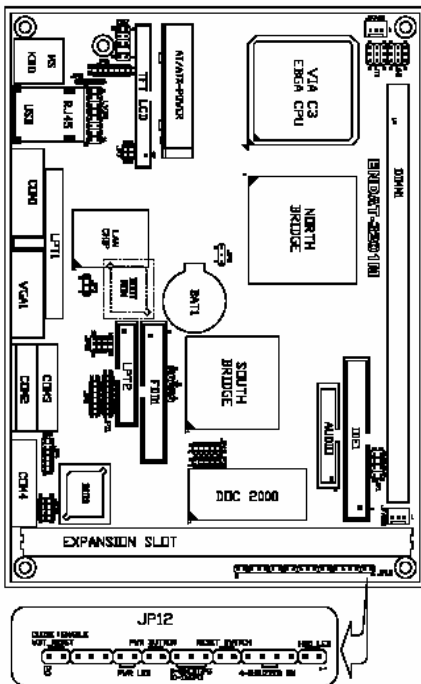

Chapter 2. Setting up the 6109 CPU board

Jumpers and Connectors

Jumpers/Connectors Overview:

Function	Jumpers/Connectors
Cooling Fan Connector	JFAN1, JFAN2
Power Supply: Power Good	JP12: Pin 9-11
ATX Power On/Off Switch	JP12: Pin 12-13
Audio Port Connector	CN1
2nd Printer Port	CN4
LAN Adapter Disable/Enable	JP3
COM1 Port	CN6
COM2 Port	CN8
COM3 Port	CN2
COM4 Port	CN3
COM Ports Power Selector (COM1, 2, 3, 4)	JP4, JP9
RS232/RS422/RS485 Selector (COM2)	JP10, JP11
DiskOnChip Memory Address	JP15
LCD: TFT LCD Panel Connector	LCD-CON1
LVDS LCD Output Port	CN5
LVDS Voltage Selector	JP5
Clear CMOS	JP2
Factory Setting	JP1, JP7, JP8, JP13, JP14, JT1, JH1
PS/2 Keyboard Jack	JKBMS
PS/2 Mouse Jack	JKBMS
PS/2 Mouse/KB Pin Header	CN7
IR	J1
FDD Connector	FDD1
IDE 1	IDE1
Header for Case Panel	JP12
IDE 1 LED	JP12: Pin 1, Pin 2

Function	Jumpers/Connectors
External Speaker	JP12: Pin 3, Pin 6
Buzzer On/Off	JP12: Pin 4, Pin 5
Hardware Reset Switch	JP12: Pin 7, Pin 8
External Power Good	JP12: Pin 9, Pin 10
Internal Power Good	JP12: Pin 10, Pin 11
ATX Power Supply On/Off Switch	JP12: Pin 12, Pin 13
Power LED	JP12: Pin 14, Pin 15
WDT Function Enable/Disable	JP12: Pin 19, Pin 20

Please double-check the insertion and orientation of the LCD cable before applying power : mproper installation will result in permanent damage LCD panel.

JP2: CMOS Data Clear:

Pin 1-2 *	Normal
Pin 2-3	Clear CMOS Data

JP15: DiskOnChip Memory Address Selector

JP15		Memory Address
1-2	7-8	0C800H-0C9FFH
1-2	9-10	0CC00H-0CDFFH
3-4	7-8	0DCCCH-0D1FFH
3-4	9-10	0D400H-0D5FFH
5-6	7-8	0D800H-0D9FFH(Default)

JP3: On-board LAN Disable/Enable

Pin 1-2	Enable On-Board LAN
Pin 2-3	Disable On-Board LAN

JP9 (COM1, 2) / JP4 (COM3, 4) Voltage Selector:

Voltage	COM1(JP9)	COM2(JP9)	COM3(JP4)	COM4(JP4)
+12V(dc)	1-2	7-8	1-2	7-8
R.I.	3-4	9-10	3-4	9-10
+5V(dc)	5-6	11-12	5-6	11-12

JP10, JP11: RS232 / 422 / 485 Selector for COM2

TYPE	JP10	JP11
RS-232	1-2, 4-5, 7-8, 10-11	1-2
RS-422/485 Full Duplex	2-3, 5-6, 8-9, 11-12	3-4, 7-8

* Make sure the port mode is set up correctly before installing any peripherals.

JP12's Pin 9~11: On-board Power Good Selector

Pin 9-10	Using External Power Good
Pin 10-11	Using On Board Power Good

JFAN1, JFAN2: CPU / 2nd Cooling Fan Connector

Pin No.	Function
Pin 1	Sensor Pin.
Pin 2	+12V
Pin 3	GND

JP12's Pin12;13;16;17;18: For ATX Power Supply

Close Pin 16-17	Using PS/2 AT Power Supply
Close Pin 17-18	Using ATX Power Supply
Pin 12; Pin 13	On/Off Switch for ATX Power

12: Case Panel Connection:

Pin No.	Description
1,2	HDD_LED -/+
3,6	External Speaker
4,5	Onboard Buzzer

7-8	Hardware RESET
9-10	Reserved
10-11	Reserved
12-13	ATX Power On/Off
14-15	Power LED (14:LED+, 15:LED-)
16-17	Close for PS/2 Power
17-18	Close for ATX Power
19-20	Close: Enable WDT function

J1: IR Pin Header.

Pin No.	Function
1	+5V(DC)
2	N.C.
3	IRRX
4	GND.
5	IRTX

CN1: Audio Output Port connector via AV Card Kit (Optional)

Please close pin13-14 to disable onboard Audio features if the AV Card Kit is not inserted onto the CN1 connector. If AV card kit is inserted, please make sure the BIOS is enabled with the audio function, since LPT2 and audio function can not be used in the same time

CN1: Audio Port.

Pin No.	Function	Pin No.	Function
1	BITCLK	2	GND
3	SDIN	4	N.C.
5	SDIN2	6	N.C.
7	SDOUT	8	N.C.
9	SYNC	10	GND
11	-ACRST	12	GND
13	SPEAK	14	Strapping Low
15	+5V(DC)	16	+12V(DC)

17	JBCY	18	JAB2
19	JBCX	20	JAB1
21	JACY	22	JBB2
23	JACX	24	JBB1
25	MSO	26	MSI

CN7: Pin Header for PS2 KB / MS

Pin No.	Signal (KB)	Pin No.	Signal(MS)
1	KB Data	2	MS Data
3	KEY	4	KEY
5	GND	6	GND
7	+5V(DC)	8	+5V(DC)
9	KB_CLK	10	MS_CLK

Printer (LPT1/LPT2) Port

Pin No.	Description	Pin No.	Description
1	STB#	10	ACK#
2	PD0	11	BUSY
3	PD1	12	PE
4	PD2	13	SLCT
5	PD3	14	AFD#
6	PD4	15	ERR#
7	PD5	16	INIT#
8	PD6	17	SLIN#
9	PD7	18-25	GND

JP5: Voltage Selector for LDVS Receiver

Pin No.	Signal
1-2	Receiver = +5V(DC) Type
2-3	Receiver = +3.3V(DC) Type
4-5	Open for OEM. Type

	Close for Normal Type
--	-----------------------

* Caution: Improper setting will damage LCD panel.

CN5: LCD - LVDS Output.

Pin No.	Signal	Pin No.	Signal
1	Y0-	2	Y2-
3	Y0+	4	Y2+
5	Y1-	6	Rcv. Voltage
7	GND	8	Y3-
9	Y1+	10	Y3
11	CK-	12	VDD_PNL
13	CK+	14	DISP_OFF
15	VBL	16	GND

LCD_CON1: TFT LCD Panel Port

Pin No.	Signal	Pin No.	Signal
1	VBL	2	VBL
3	GND	4	GND
5	VDDLCD	6	VDDLCD
7	ENPVEE	8	GND
9	FPD 23	10	FPD 22
11	FPD 17	12	FPD 16
13	FPD 11	14	FPD 10
15	FPD 9	16	FPD 8
17	FPD 21	18	FPD 20
19	FPD 15	20	FPD 14
21	FPD 7	22	FPD 6
23	FPD 5	24	FPD 4
25	FPD 19	26	FPD 18
27	FPD 13	28	FPD 12
29	FPD 3	30	FPD 2

31	FPD 1	32	FPD 0
33	GND	34	GND
35	P_CLK	36	FLM
37	DE	38	LP
39	GND	40	PBKL
41	PNKL	42	KEY
43	VCC	44	VCC

* Please make sure the Pin 1 location before inserting the LCD connector.

Factory Setting:

JP1: All Pin Open

JP7: Close Pin 1-3, Pin 4-6

JP8: Close Pin 1-2

JP13: Factory Using only

JP14: Close Pin 2-3; Pin 5-6; Pin 8-9; Pin 11-12

JT1: Close Pin 2-3; Pin 4-5; Pin 8-9

JH1: Close Pin 1-2; Pin 5-6; Pin 7-8

2-4. Installing Memory

The NASA-6109 CPU board offers one 168pin DIMM sockets

supporting up to 512MB of memory. The DIMM memory can be 100MHz (PC-100) or 133 MHz (PC-133).

2-5. Shared VGA Memory

The NASA-6109 is using built-in AGP VGA controller with share memory architecture (SMA) - AGP mode with 2MB to 8MB of system memory. The amount of video memory on motherboard determines the number of colors and the video graphic resolution.

2-6. Installing Riser Card

Installing Riser Card (Max. 3 PCI Slot on Riser Card)

PCI Slot	INT	ADSEL
PCI 1	A,B,C,D	AD24(Onboard LAN)
PCI 2	B,C,D,A	AD23
PCI 3	C,D,A,B	AD22
PCI 4	D,A,B,C	AD21

There are two different riser cards that can be fitted to NASA-6109 CPU board. The first one is a 98pin ISA only Bus riser card (traditional ISA Bus riser card), the second one is a 188pins PCI/ISA riser card.

Please note: PCI/ISA riser cards jumper settings have to be matched with the motherboard INT/AD-select jumper.

The default INT/AD-select for NASA-6109/3601M All-In-One motherboard is listed in the above table. However, it could be revised by changing JP14 setting for different INT/AD-select. The following table shows the variable configurations:

INT/AD Configurations:

Expansion for PCI Slot	* Close 1-2	Close 2-3
Expansion PCI 1	INT =A,B,C,D	INT = B,C,D,A
Expansion PCI 2	INT = B,C,D,A	INT = C,D,A,B
Expansion PCI 3	INT = C,D,A,B	INT = D,A,B,C
Expansion PCI 4	INT = D,A,B,C	INT = A,B,C,D

Note: Even change the setting for different configuration the AD-select should be match to each INT. Please using the default setting as above if you are not familiar with the configuration of raiser card and add-on card.

Caution: Do not insert PCI Bus Add-On cards directly into the on-board expansion slot!

2-6. Assigning IRQs for Expansion Cards

Some expansion cards require an IRQ (Interrupt request vector) to operate. Generally, each IRQ must be exclusively assigned to specific use. In a standard design, there are 16 IRQ available with 11 of them already in used by other part of the system.

Both ISA and PCI expansion cards may need to use IRQ. Cards installed in the ISA Expansion Bus have the first priority to use the available system IRQs. Any remaining IRQ then, may be assigned to this PCI Bus. Microsoft's Diagnostic (MSD.EXE) utility included in the Windows directory can be used to see their map. Make sure that there are no two devices using the same IRQ in the system. Otherwise this will cause the system to hang up or give unexpected results. To simplify the process, this motherboard complies with the Plug and Play (PnP) specifications, which was developed to allow automatic system configuration. Whenever a PnP-compliant card is added to the system, PnP cards and IRQs are automatically assigned if available. If the system has both Legacy and PnP ISA cards installed. IRQs are assigned to PnP cards from those not used by Legacy cards. The PCI and PnP configuration in the BIOS setup utility can be used to indicate

which IRQs have being used by Legacy cards. For older Legacy cards that do not work with the BIOS, you can contact your vendor for an ISA configuration utility.

An IRQ number is automatically assigned to PCI expansion cards after those used by Legacy and PnP ISA cards. In the PCI Bus design, the BIOS is automatically assigned an IRQ to a PCI slot that has a card in it which requires an IRQ. To install a PCI card, you need to set the correct "ADSEL" and "INT" (interrupt) assignment. Please refer to "Chapter 2-5" Installing a Riser Card for detail assignments.

IRQ	Status	Assignment
0	Used	Timer
1	Used	Keyboard
2	Used	Second 8259
3	Used	COM2
4	Used	COM1
5	Used	COM3
6	Used	Floppy Disk
7	Used	LPT1
8	Used	RTC
9	Used	LPT2 or Audio
10	Used	COM4
11	Used	LAN Adapter (on board)
12	Used	PS/2 Mouse
13	Used	Coprocessor
14	Used	Hard Disk (IDE 1)
15	Used	Reserved (IDE 2)

2-8. Assigning DMA Channels for ISA Cards

Since ISA cards, both Legacy and PnP may also need to use a DMA (direct memory access) channel, DMA assignments for this motherboard are handled the same way as the IRQ assignment process described above. You can select a DMA channel in the PCI and PnP configuration section of the BIOS setup utility. In the BIOS setup, you should choose "Yes" for those IRQ's and DMA's you wish to reserve for Legacy cards.

Chapter 3. AMI BIOS SETUP

AMI BIOS Setup Main Menu

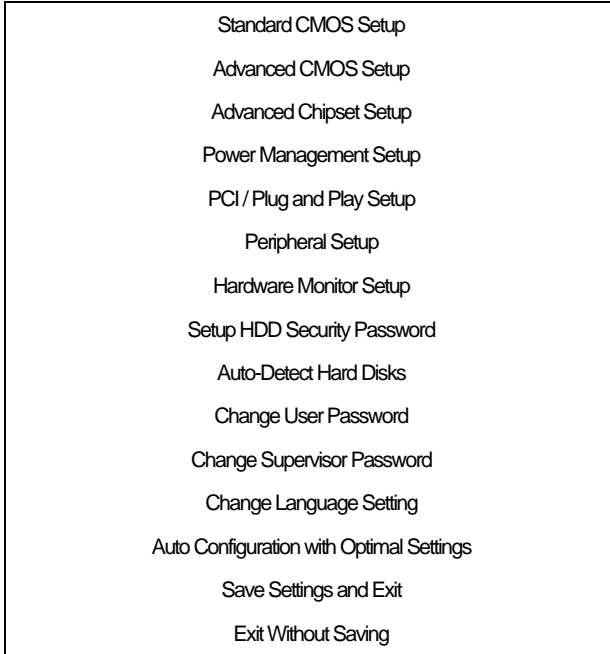

Use the CMOS setup program to modify the system parameters to reflect the environment installed in your system and to customize the system as desired. Press the key to enter into the CMOS setup program when you turn on the power. Settings can be accessed via arrow keys. Press <Enter> to choose an option to configure the system properly. In the main menu, press F10 or "SAVE & EXIT SETUP" to save your changes and reboot the system. Choose "EXIT WITHOUT SAVING" to ignore the changes and exit the setup procedure. Pressing <ESC> at anywhere during the setup will return to the main menu. "Advanced CMOS Setup", "Details of the Advanced Chipset Features" and "PCI / Plug and Play Setup" requires board knowledge on PC/AT system architecture and VIA chipset specification. They intend to be used by well-trained technicians and experienced users. Incorrect setup could cause system malfunctions.

3-1. Quick Setup

3-2. In most cases, you can quickly configure the system by using the following procedure.

The manufacturer highly recommends that you use "Quick Setup" for setting CMOS to avoid any unpredictable results. Choose "Standard CMOS Setup" from the main menu, to configure the date and time, hard disk type, floppy disk drive type etc.

Choose "Auto Configuration with Optimal Setting" from the menu for loading the defaults parameters that is set by the manufacturer for the most stable normal configuration.

Press F10 or "Save Setting and Exit" to save the changes and reboot the system.

3-2. Description of the BIOS Setup Option

Please make clear the means of those optional parameters. Improper settings will cause the system to hang up or perform poorly. Most items are clearly understood from the screen prompt or "Help" by function key "F1". The manufacturer highly recommends that "Default" settings have been used to avoid any unpredictable results.

3-3. Advanced CMOS Setup

Advanced CMOS Setup

Quick Boot	Enabled
1st Boot Device	Floppy
2nd Boot Device	IDE-0
3rd Boot Device	CDROM
4th Boot Device	Disabled
Try Other Boot Devices	Yes
S.M.A.R.T. for Hard Disks	Disabled
BootUp Num-Lock	On
Floppy Drive Swap	Disabled
Floppy Drive Seek	Disabled
PS/2 Mouse Support	Enabled
Typematic Rate	Fast
System Keyboard	Present
Primary Display	VGA/EGA
Password Check	Setup
Boot To OS/2	No
System BIOS Cacheable	Enabled
C000, 32k Shadow	Cached
C800, 16k Shadow	Disabled
CC00, 16k Shadow	Disabled
D000, 16k Shadow	Disabled

D400, 16k Shadow	Disabled
D800, 16k Shadow	Disabled
DC00, 16k Shadow	Disabled

S.M.A.R.T. For Hard Disks

Set this option to “Enabled” to permit AMIBIOS to use the SMART (System Management System Management and Reporting Technologies) protocol for reporting server system information over a network. The settings are “Enabled” or “Disabled”.

Password Check

This option enables password checking every time the system boots or when you run AMIBIOS Setup. If Always is chosen, a user password prompt appears every time the computer is turned on. If Setup is chosen, the password prompt appears if AMIBIOS is executed. See the Advanced Setup chapter for instructions on changing a password.

Boot To OS/2

Set this option to “Enabled” if running OS/2 operating system and using more than 64 MB of system memory on the motherboard. The settings are “Enabled” or “Disabled”.

System BIOS Cacheable

When set to “Enabled”, the contents of the F0000h system memory segment can be read from or written to cache memory. The contents of this memory segment are always copied from the BIOS ROM to system RAM for faster execution. The settings are “Enabled” or “Disabled”.

3-4. Details of the Advanced Chipset Setup

Advanced Chipset Setup

***** DRAM Timing *****	
Configure SDRAM Timing by SPD	Enabled
DRAM Frequency	133Mhz
SDRAM CAS# Latency	3
DRAM Bank Interleave	Enabled
Memory Hole	Disabled

AGP Mode	4x
AGP Read Synchronization	Enabled
AGP Fast Write	Disabled
AGP Aperture Size	128MB
AGP Master 1 W/S Write	Disabled
AGP Master 1 W/S Read	Disabled
PCI Delay Transaction	Enabled
USB Controller	All USB Port
USB Device Legacy Support	All Device

Configure SDRAM Timing by SPD

SPD (Serial Presences Detect) is a device in memory module for storing the module information such as DRAM timing and chip parameters. If this option is enabled, BIOS will access SPD automatically to configure module timing. If disabled, DRAM timing can be configured manually.

SDRAM Frequency

- Allows you to set the SDRAM frequency with user set by SPD Disable. <Choices: 66MHz / 100MHz / 133MHz>

Caution: Improper setting will cause unpredicted result

SDRAM CAS# Latency

With SDRAM Timing by SPD disabled, you can select

- The SDRAM CAS# (Column Address Stroke) latency manually. Choices: 2 Clocks; 3 Clocks

SDRAM Bank Interleave

This function is to enable / disable SDRAM Bank Interleave function. Choices: "Disabled" / "Enabled"

Memory Hole

To enabled / disabled (default) the support of Memory Hole which is reserved for ISA card.

AGP Mole

This function allows seeing the AGP Mode onboard. The default setting is "Auto". This item support 1x/2x and 4x AGP Mode

AGP Read Synchronization

To enabled / disabled the AGP Read Synchronization function.

AGP Fast Write

This function allows enabling / disabling the AGP Fast Write function

AGP Aperture Size

This function allows adjusting AGP Aperture Size from 2MB to 256MB to increased VGA performance.

AGP Master 1 W/S Write

Allows you to enable / disable the AGP Master Write with 1 wait state

AGP Master 1 W/S Read

To enable / disable the AGP Master Read with 1 wait state

PCI Delay Transaction

To enable / disable the AGP Fast Write function

USB Controller

To enable / disable the on board USB Port function

Choices: USB Port 0&1 / USB Port 2&3 / All USB Device

USB Device Legacy Support

To enable / disable the on board USB support device with

Choices: Disabled / No Mice / All Device

3-5. Peripheral Setup

Peripheral Setup

OnBoard FDC	Enabled
OnBoard Serial Port 1	3F8/COM1
OnBoard Serial Port 2	2F8/COM2
OnBoard Parallel Port	378
Parallel Port Mode	ECP
EPP Version	N/A
Parallel Port DMA Channel	3
Parallel Port IRQ	7
OnBoard Serial Port 3	3E8/COM3
Serial Port3 IRQ	9
OnBoard Serial Port 4	2E8/COM4
Serial Port4 IRQ	10
OnBoard Parallel Port 2	Disabled
OnBoard AC'97 Audio	Enabled
OnBoard Legacy Audio	Enabled
Sound Blaster	Enabled
SB I/O Base Address	220h-22Fh

SB IRQ Select	5
SB DMA Select	1
MPU-401	Enabled
MPU-401 I/O Address	330h-333h
FM Port (388h-38Bh)	Enabled
Game Port (200h-207h)	Enabled

Onboard FDC

Set this option to "Enabled" to enable the floppy drive controller on the motherboard. The settings are Auto (AMIBIOS automatically determines if the floppy controller should be Enabled, or Disabled).

Onboard Serial Port 1/2/3/4

This option specifies the base I/O port address of serial port. The settings are Auto (AMIBIOS automatically determines the correct base I/O port address), Disabled, 3F8h, 2F8h, 2E8h, or 3E8h.

Onboard Parallel Port

This option specifies the base I/O port address of the parallel port on the motherboard. The settings are Disabled, 378h, 278h, or 3BCh. The Optimal default setting is 378h

Parallel Port Mode

This option specifies the parallel port mode. The Optimal default setting is Normal. The settings are:

Setting	Description
Normal	The normal parallel port mode is used.
Bi-Dir	Use this setting to support bidirectional transfers on the parallel port.
EPP	The parallel port can be used with devices that adhere to the Enhanced Parallel Port (EPP) specification. EPP uses the existing parallel port signals to provide asymmetric bidirectional data transfer driven by the host device.
ECP	The parallel port can be used with devices that adhere to the Extended Capabilities Port (ECP) specification. ECP uses the DMA protocol to achieve data transfer rates up to 2.5 Megabits per second. ECP provides symmetric bidirectional communication.

EPP Version

This option specifies the Enhanced Parallel Port specification version number that is used in the system. This option only appears if the Parallel Port Mode option is set to EPP. The settings are 1.7 or 1.9.

Parallel Port IRQ

This option specifies the IRQ used by the parallel port. The settings are Auto, (IRQ) 5, or (IRQ) 7.

Parallel Port DMA Channel

This option is only available if the setting for the Parallel Port Mode option is ECP. This option sets the DMA channel used by the parallel port. The settings are DMA Channel0, 1, or 3.

Serial Port IRQ

This option specifies the IRQ used by the serial port. The settings are Auto, (IRQ) 5, or (IRQ) 7

Onboard AC'97 Audio

This function is to disable or enable AC'97 Audio. Choices: Auto; Disabled

Onboard Legacy Audio

This function allows configuring the Audio Codec to support legacy Sound Blaster mode. Choices: Auto; Disabled

Sound Blaster

This option is to Enable / Disable the onboard Audio support Sound Blaster decoding.

SB I/O Base Address

To configure the Sound Blaster decoding I/O range.

Choice: 220h – 280h

SB IRQ Select

To configure Sound Blaster IRQ channel.

Choice: 5,7 and 10

SB DMA Select

To configure Sound Blaster DMA channel.

Choice: 0,1,2 and 3

MPU-401

This option is to Enable / Disable onboard MIDI port decoding.

MIPU-401 I/O Address

If the onboard MPU-401 port is "Enabled", it allows to set at 300h/310h/320h or 330h.

FM Port (388h-38Bh)

Allows you to Enable / Disable onboard FM Port synthesis for legacy compatibility

MPU-401

Allows you to Enable / Disable onboard MIDI port,

Game Port (200h-270h)

This option allows configuring onboard Game port address. The choices: Disabled; 200h; 207h

3-6. Power Management Setup

Power Management Setup

Power Management/APM	Enabled
Video Power Down Mode	Disabled
Hard Disk Power Down Mode	Disabled
Standby Time Out (Minute)	Disabled
Suspend Time Out (Minute)	Disabled
Display Activity	Ignore
IRQ3	Monitor
IRQ4	Monitor
IRQ5	Ignore
IRQ7	Monitor
IRQ9	Ignore
IRQ10	Ignore
IRQ11	Ignore
IRQ13	Ignore
IRQ14	Monitor
IRQ15	Ignore
Power Button Function	On/Off
Restore on AC/Power Loss	Power On

Power Management/APM

Set this option to Enabled to enable the chipset power management and APM (Advanced Power Management) features. The settings are Enabled or Disabled.

Video Power Down Mode

This option specifies the power state that the video subsystem enters when AMIBIOS places it in a power saving state after the specified period of display inactivity has expired. The settings are Standby, Suspend or Disabled.

Hard Disk Power Down Mode

This option specifies the power conserving state that the hard disk drive enters after the specified period of hard drive inactivity has expired. The settings are Disabled, Standby, or Suspend.

Standby/Suspend Timer Unit

This option specifies the unit of time used for the Standby and Suspend timeout periods. The settings are 4 msec, 4 sec, 32 sec, or 4 min.

Display Activity

When set to Monitor, this option enables event monitoring on the video display. If set to Monitor and the computer is in a power saving state, AMIBIOS watches for display activity. The computer enters the Full On state if any activity occurs.

AMIBIOS reloads the Standby and Suspend timeout timers if display activity occurs. The settings are Monitor or Ignore.

Power Button Function

This option specifies how the power button mounted externally on the computer chassis is used. The default setting is On/Off.

Restore on AC/Power Loss

Power "Off" Set Restore on AC/Power Loss is Power off. Power "On" Set Restore on AC/Power Loss is Power on.
(Default Value)

3-7. PCI / Plug and Play Setup

This section describes the configuration of the PCI bus system. PCI is a system that allows I/O device to operate at speeds nearing the speed of the CPU itself, when communicating with its own special components. This section covers some very technical items. It is strongly recommended that only experienced users make any changes to the default settings.

PCI / Plug and Play Setup

Plug and Play Aware O/S	No
OnChip VGA Frame Buffer Size	8MB
PCI Latency Timer (PCI Clocks)	32
Primary Graphics Adapter	PCI
Display Device	CRT Only
LCD Resolution	640 X 480
DMA Channel 0	PnP
DMA Channel 1	PnP
DMA Channel 3	PnP
DMA Channel 5	PnP

DMA Channel 6	PnP
DMA Channel 7	PnP
IRQ3	ISA/EISA
IRQ4	SA/EISA
IRQ5	PCI/PnP
IRQ7	ISA/EISA
IRQ9	PCI/PnP
IRQ10	PCI/PnP
IRQ11	PCI/PnP
IRQ14	PCI/PnP
IRQ15	PCI/PnP

Plug and Play Aware O/S

Set this option to Yes to inform AMIBIOS that the operating system can handle plug and Play (PnP) devices. The settings are No or Yes. The Optimal and Fail-Safe default settings are No.

Display Device

Select the display device for system. The available options are CRT Only, CRT + LCD.

LCD Resolution

Select the display resolution for LCD panel. The available options are 640x480, 800x600, 1024x768.

PCI Latency Timer (PCI Clocks)

This option specifies the latency timings (in PCI clocks) for PCI devices installed in the PCI expansion slots. The settings are 32, 64, 96, 128, 160, 192, 224, or 248.

IRQ3/4/5/7/9/10/11/14/15 Assigned to

These options specify the bus that the specified IRQ line is used on. These options allow you to reserve IRQs for legacy ISA adapter cards. These options determine if AMIBIOS should remove an IRQ from the pool of available IRQs passed to devices that are configurable by the system BIOS. The available IRQ pool is determined by reading the ESCD NVRAM. If more IRQs must be removed from the pool, the end user can use these options to reserve the IRQ by assigning an ISA/EISA setting to it. Onboard I/O is configured by AMIBIOS. All IRQs used by onboard I/O are configured as PCI/PnP. IRQ12 only appears if the Mouse Support option in Advanced Setup is set to Disabled. IRQ14 and 15 will not be available if the onboard PCI IDE is enabled. If all IRQs are set to ISA/EISA and IRQ14 and 15 are allocated to the onboard PCI IDE, IRQ9 will still be available for PCI and PnP devices, because at least one IRQ must be available for PCI and PnP devices. The settings are ISA/EISA or PCI/PnP. The Optimal and Fail-Safe default settings are PCI/PnP.

DMA0/1/3/5/6/7 Assigned to

These options allow you to specify the bus type used by each DMA channel. The settings are PnP or ISA/EISA .

3-8. Hardware Monitor Setup

Provide some information such as CPU temperature, speed of cooling fan and usage voltage of CPU for user.

Chapter 4. VGA, LCD, DOC Featur

4-1. AGP-BUS VGA Feature

The NASA-6109 built-in Graphics Controller is a fully integrated 64-bit 2D/3D Accelerator. The high performance graphics engine offers high speed 3D image processing in full compliance and compatibility with IBM® VGA and VESA™ extended VGA.

The on-board Graphics Controller supports a full AGP implementation internally to remain compatible with existing software and programming models. However, since the engine is integrated it enjoys a higher bandwidth and lower latency than is possible with discrete solutions. The Controller also supports two simultaneous displays: CRT, Flat Panel Monitor.

The on-board Graphics Controller's main system features include:

High Performance single cycle GUI

- Highly Integrated RAMDAC™ and Triple Clock Synthesizer
- Full Feature High Performance 3D Graphics Engine
- High speed internal AGP Bus Mastering data bus supporting DVD video playback & 3D
- Hardware implementation of motion compensation
- Dual Video Windows for Videoconferencing
- Versatile Motion Video Capture/Overlay/Playback Support
- Flexible Frame Buffer Memory Interface
- Advanced Mobile Power Management and CRT Power Management (VESA™ DPMS)
- PC99 Hardware Support

4-2. LCD Flat Panel Feature

Flat Panel Monitor Interface

The on-board graphic controller also support industry standard TFT LCD panel, the interface supports both 18-bit and 24-bit display modes. Optionally, an 18+18 panel can be supported utilizing external latches (UC-1818L). On-board also support LVDS interface to provide a low voltage, high speed, low EMI serial DC-balanced differential data via

external LVDS transmitters to support TFT LCD Panel with LVDS built-in.

The flat panel interface provides or supports the following functions for various panels:

- Generates flat panel interface signals like FLM, LP, SCLK, and DE
- Generates different video data formats to directly drive different types of panels
- Vertical and horizontal expansion of video displays to LCD panel resolution
- Vertical and horizontal centering
- Panel power sequence

4-3. PCI Bus Audio Adapter Features

The Chipset built-in SoundBlaster Pro Hardware and Direct Sound Ready AC97' Digital Audio Controller

- Dual full-duplex direct sound channels between system memory and AC97' link
- PCI Master interface with scatter / gather and bursting capability
- 32byte FIFO of each direct sound channel
- Host based sample rate converter and mixer
- Standard v1.0 or v2.0 AC98' Codec interface for single or cascaded AC97' Codec's from multiple vendors
- Loop back capability for re-directing mixed audio streams into USB and 1394 speakers
- Hardware SoundBlaster Pro for Windows DOS box and real-mode DOS legacy compatibility
- Plug and Play with 4 IRQ, 4 DMA and 4 I/O space options for SoundBlaster Pro and MIDI hardware
- Hardware assisted FM synthesis for legacy compatibility
- Complete software driver support for Windos-95, Windows-98 and Windows-NT

4-4. DiskOnChip Feature

On board reserved is a 32-pin Socket for DiskOnChip 2000, it is a unique data storage solution to offer a better, faster and more cost effective Flash Disk for applications.

The DiskOnChip 2000 provides a Flash Disk (as BIOS expansion) that does not require any additional bus, slot or connector. Simply insert the DiskOnChip 2000 into a 32-pin socket on your motherboard. With minimal installation costs, you have a bootable Flash Disk. DiskOnChip 2000 has built-in True FFS (True Flash File System) technology, which provides full Read/Write disk emulation.

True FFS provides hard disk compatibility at both the sector and file level. It works in a variety of operating system environments, such as DOS, Win95, WinCE, WinNT, Psos+ and QNX.

The correct memory address must be set correctly for DiskOnChip at the jumper JP15. The driver utilities are placed onto CD-ROM

JP15	Memory Address
1-2	0C800H - 0C9FFH
1-2	0CC00H - 0CDFFH
3-4	0DCCCH - 0D1FFH
3-4	0D400H - 0D5FFH
5-6	0D800H - 0D9FFH

4-5. Driver Utility Installation Guide

1. When finishing with the Windows platform (95/98/2000/NT) installation, please install the relative VIA driver (4in1) utilities for compliance of the compatibility with hardware environment.
2. Insert the support CD that came with your motherboard into your CD-ROM driver which will access with auto-run mode or double –click the CD driver icon in “My Computer” to bring up the screen.
3. Select correct mother you have to install driver / utility you're your system



4. Select VIA 4in1 service pack driver install to the system

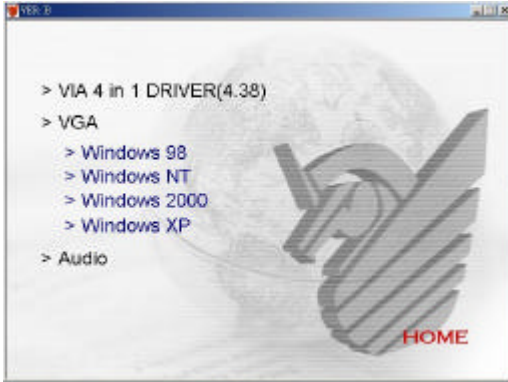

5. The Screen will appear VIA 4in1 driver setup screen, please press “NEXT” to continue. Please follow the steps instructed by each screen for the installation of the VIA 4in1 driver. Restart the system after the completion of the installation.

6. After VIA 4in1 driver installed, please select VGA driver for install. The system will request for “restart” after the completion of the driver installation.

7. The Screen can be adjusted at Display properties after the installation of VGA driver.

We strongly recommend using the 4in1 driver to install the system since the 4in1 driver will automatically detect / update the necessary drivers.

This driver will automatically detect and install the latest utilities as following:

IDE Bus master , VIA AGP Driver, IRQ Routing Driver, VIA INF Driver

LAN Driver: Install the LAN driver for on-board LAN adapter. Please refer to Chapter 5, the Realtek 8139 LAN Driver Installation Procedure.

VGA Driver: Install the VGA driver for on-board AGP VGA adapter

Please download or check from VIA Web-site: www.via.com.tw if you prefer to install the drivers individually or you need more information.

Chapter 5. LAN Adapter

The on-board LAN adapter use of Single Chip Fast Ethernet Controller, that is highly integrated and requires no “glue” logic external memory on board. It runs in the bus master mode and directly sending/receiving Ethernet packet to/from memory. The On-board LAN adapter can directly fetch the system CPU. Also, it can transfer data Directly between I/O devices and system memory in the 32-bit bus master mode that provides low CPU utilization.

It complies with the IEEE 802.3u standard, IEEE802.3 standard and PCI Local Bus version 2.1 and transmits data on the network at 100 Mbps or 10 Mbps. It also operates in full-duplex mode that doubles the network speed up to 20/200 Mbps when working with Fast Switching Hub. Built-in one RJ-45 port for connection of 100Base-TX Fast Ethernet or 10Base-T Ethernet network, and automatically senses the connection type.

5-1. Features

- Full compliancy with PCI Rev. 2.1
- Complies with the Ethernet/IEEE 802.3u 100Base-TX and 10 Base-T industry standard
- Supports full-duplex operations, thus doubling the network speed up to 20Mbps on 10 Base-T Ethernet or 200Mbps on 100 Base-TX Fast Ethernet when setting in full duplex mode
- Two LED indicators to report network status
- One RJ-45 connector with Auto-sense cable type of 10 or 100Mbps network operation
- Supports PCI clock speed up to 33MHz, capable of zero wait states
- Supports optional Remote Boot ROM socket
- Provides a comprehensive setup program for displaying the adapter configuration and includes diagnostic on board or network tests.
- Complete drivers for Novell, ODI, SCO UNIX, LAN Manager, Windows NT and Windows 95/98 Packet driver etc

5-2. UTP Cable / RJ-45 Jack Definition

Straight through twisted pair cable is typically used to connect a hub to a server or workstation. In a straight through connection, Pin 1 at the server, Pin 2 at the hub connects to Pin 2 at the server, and so on. Figure A-1 shows the locations of pins on a standard RJ-45 plug on a twisted-pair cable.

Table A-1 shows the wiring in a straight-through twisted-pair cable (Pins 4,5,7 and 8 are not used).

Twisted Pair Number	Pin Number	Signal Description	To	Pin Number	Signal Description
1	1	TD+	→	1	TD+
	2	TD-		2	TD-
2	3	RD+	→	3	RD+
	6	RD-		6	RD-

RJ-45 Connector Pin Assignments

Figure A-1 shows the RJ-45 Connector pin assignments

RJ45 PIN AND CABLE COLORS

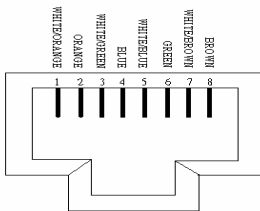

5-3. Connecting 100Base-TX Fast Ethernet Network

The system board provides an RJ-45 port for connection to 100Base-TX Fast Ethernet or 10Base-T Ethernet Network with a single connection over unshielded twisted-pair (UTP). The adapter automatically operates at 10Mbps or 100Mbps when the appropriate 10/100Base hub be connected.

To connect the adapter to 100Base-TX Fast Ethernet Network, you need a twisted-pair Category 5 cable with RJ-45 modular jacks at both ends. This cable can have a maximum length of 300 feet (100 meters).

5-4. Connecting 10Base-T Ethernet Network

To connect the adapter to a 10Base-T Ethernet Network, you need a twisted-pair Category 3, 4 or 5 cables with RJ-45 modular jacks at both ends. This cable can have a maximum length of 300 feet (100 meters).

5-5. 10MBase/100MBase Installation Notice

- 100Mbps network must be shielded twisted-pair (STP) or Category 5 unshielded twisted-pair cable. Do not use a Category 3 or 4 cable for 100Mbps-network operation, it could cause data loss. Category 3 or 4 cable is good for

10Mbps network only.

- Category 5 cable is also good for 10Mbps operation. Use UTP Category 5 cable for the versatility to operate the network at either 100Mbps or 10Mbps speed without changing cable.
- Two pairs of wiring are required.
- Depending on building codes, different insulation materials may be required. Plenum-rated or TEFLON-coated wiring may be required in some areas where fire proofing is required.
- The wire gauge should be between 18 and 26AWG (Most telephone installations use 24-gauge wiring).
- UTP cable should meet the following requirements:
 1. Solid copper
 2. Nominal capacitance: less than 16pF/ft
 3. Nominal impedance: 100 ohms
 4. Nominal attenuation: less than 11.5db

Automatic Selection of the Media Type

While the driver installs, it automatically detects the media type based on the type of cable connected. Once you change the cable type, you must reinstall the driver to execute auto-detect again.

If the driver cannot detect which cable is connected or whether a cable is connected, look at cabling network driver (Ex. Modify net.cfg file parameters—force line speed=10 or 100).

10/100 Auto – Negotiation (N-Way)

Depending on the hub or connected device, the LAN adapter can automatically run at the appropriate speed, by using N-way, a feature that complies with the IEEE802.3 standard. It also works with any of the other IEEE-compliant products.

5-6. Remote BOOT ROM Installation Guide

A BOOT ROM allows the computer to boot up over the network, instead of using the local operating system device.

This enables the system to be a diskless workstation environment.

1. Make sure the BOOT ROM is properly oriented. Incorrect orientation may damage the chip!
2. Use the utility of RSET8139.exe to enable the BOOT ROM.
3. Reboot the system to use the BOOT ROM function.

BOOT ROM Type:

Once the PCI system detects the presence of a BOOT ROM chip on the adapter during boot-up, it will automatically set a working configuration. Supports 64K FLASH ROMs (PLCC Type) for an upgrade BOOT ROM.

5-7. LED Indicators

The system board comes with two LED indicators on the edge of the motherboard that indicates the network system status. If you experience any problems with the adapter, first make sure the appropriate driver is loaded, the proper cable is connected to the RJ-45 port and the hub complies with the adapter specification, such as 10Mbps 10Base-T or 100Mbps 100Base-TX. Finally, recheck the LEDs.

FUDUP (Full Duplex) Indicator

When indicator is ON, it indicates Full-duplex mode; otherwise, it is OFF. The adapter supports full duplex at 10 or 100Mbps. If the switch-hub supports the N-way feature and full duplex, the system automatically runs in full duplex mode.

Tx/Rx (Transmit/Receiver) Indicator

This indicator flashes to display that there is network activity – indicating transmission or reception data from the network.

5-8. The Setup Program

The package includes a diskette containing the setup program. This program allows you to verify the configuration and isolation of faults. The adapter's I/O port address and interrupt request levels (IRQ) are set by the BIOS. Other default settings can be changed for situations as shown below. Problem (RESET8139.exe) provides the following function:

- Displays the current configuration of the adapter
- Performs network diagnostic tests to verify the operation of the adapter's basic functions, and the adapter's ability to communicate over the network with another adapter.
- Provides set up for new configuration to make a change specify settings: Remote BOOT ROM, Flow Control and Full-Duplex mode Enable/or Disable

Full duplex operation is set automatically if the Full-duplex option is set to Disable. Please follow the prompt instructions to set-up or change the system configuration.

Note: Before running the setup program, make sure the adapter's driver is not loaded, otherwise unpredictable results may arise!

The setup program can be set on board configuration to provide diagnostic testing. It is for testing the basic function verification, EEPROM data Access, loop back operation, and the ability to communicate over the network with another adapter. To access this program, insert the Driver Diskette into the floppy disk drive and then type the following at the DOS prompt:

>> A:\REST8139.EXE <ENTER>

1. View Current Configuration

This allows you to find the PCI Fast Ethernet adapter current configuration in your system.

2. Set Up New Configuration

Select New Set Up Configuration option from the main menu

The option settings can be changed, the table shown as below:

Option	Default Setting	Other Available Settings
Full-duplex	Disabled → Auto Selection	Enable – Forces to full duplex operation
Flow Control	TX Enable, RX Enable	TX Disable, RX Disable

Note: Before setting the adapter for full duplex, make sure the hub switch is also set to full duplex. Before you activate the switching hub to server connection, make sure the hub switch and adapter are configured for full duplex.

3. Run Diagnostics

Running diagnostic tests perform basic function verification for on board

LAN adapters. The basic Diagnostic tests include:

- EEPROM Test: EEPROM data read/write test
- Diagnostics On Board: Performs on board basic function verification
- Diagnostics On Network: To run this test on the network, you will need another computer set up as a Responder to receive packets from the adapter being tested and echo them back to the adapter. This checks the adapter's ability for communication over the network with another adapter to receive and transmit network packets.

4. Software Installation

Installing Network Drivers

You must install a network driver to allow the adapter to work with your network operating system.

The system board provides various network drivers on the driver diskette. The following provides the installation procedures for different network drivers.

Note: Please install the "VIA PATCH FILE" first if you want to link your LAN with Windows 98

For detailed information of each OS installation, please refer to the README (.TXT) file on the driver diskette.

Software Installation Examples

Before installing the driver programs, please refer to each directory that contains a README file, which provides detailed installation instructions, or to execute the HELP8139.EXE help file viewer in DOS. The utility will then present with a screen showing the information about how to install the network driver. Driver needed for the adapter to work with the operating system.

5-9. Realtek 8139 LAN Driver Installation Procedure:

Please note: The LAN Driver installation has to be done after completing Win 95/98/2000 installation.

When completed with the WIN 95/98 installation, please click "My Computer" to start your LAN driver installation (procedure listed as below):

My Computer → Control Panel → System → Device Manager →
? Other Devices → ?
PCI Ethernet Controller → Properties → Driver → Update Drive
→ Yes (Recommended) → Next → Other Locations → Browse
→ A:\Rtsnt.100\Exe\Win95 → OK → Finish

After finishing the above procedure, the screen will show "copy the files from?"

Please type A:\Rtsnt.100\Exe\Win95=> OK and select "OK", the system will ask you to insert Win95 driver diskette to update new driver.

After finishing the above steps, please shut down your system and re-boot the system.

Appendix A: FLASH Memory Utility

Using this utility to update the system BIOS from a disk file to the on board Flash memory. Be aware the improper change of the system BIOS will cause the system to malfunction.

Using utility as follows:

1. Insert the FLASH memory BIOS utility distribution floppy diskette in drive A:
2. At the DOS prompt, type A:\> F82725 xxxx.ROM <Enter>

D-SUB Type Connector for COM port (RS232);

Pin No.	Description	Pin No.	Description
1	DCD	6	DSR
2	RXD	7	RTS
3	TXD	8	CTS
4	DTR	9	RI
5	GND		

Box Header Type Connector for COM port (RS232);

Pin No.	Description	Pin No.	Description
1	DCD	2	DSR
3	RXD	4	RTS
5	TXD	6	CTS
7	DTR	8	RI
9	GND	10	N.C

Printer (LPT1/LPT2) Port

Pin No.	Description	Pin No.	Description
1	STB#	10	ACK#
2	PD0	11	BUSY
3	PD1	12	PE
4	PD2	13	SLCT
5	PD3	14	AFD#
6	PD4	15	ERR#
7	PD5	16	INIT#
8	PD6	17	SLIN#
9	PD7	18-25	GND

VGA Connector

Pin No.	Description	Pin No.	Description
1	RED	9	GND

Pin No.	Description	Pin No.	Description
2	GREEN	10	GND
3	BLUE	11	N.C
4	N.C	12	DDC DAT
5	GND	13	H.Sync
6	GND	14	V.Sync
7	GND	15	DDC CLK
8	GND		

FDD Connector

Pin No.	Description	Pin No.	Description
1,3,5,7	GND	14	DSA#
9,11,13	GND	16	MOB#
15,17,19	GND	18	DIR
21,23,25	GND	20	STEP#
27,29,31	GND	22	WD#
33	GND	24	WE#
2	RWC#	26	TRAK0
4,6	N.C	28	WP#
8	INDEX#	30	RDATA#
10	MOA#	32	HEAD#
12	DSB#	34	DSKCHG#

LCD - LVDS Output Connector (CN5)

Pin No.	Signal	Pin No.	Signal
1	Y0-	2	Y2-
3	Y0+	4	Y2+
5	Y1-	6	Rcv. Voltage
7	GND	8	Y3-
9	Y1+	10	Y3

11	CK-	12	VDD_PNL
13	CK+	14	DISP_OFF
15	VBL	16	GND

TFT LCD Panel Port Connector (LCD-CON1)

Pin No.	Signal	Pin No.	Signal
1	VBL	2	VBL
3	GND	4	GND
5	VDDLCD	6	VDDLCD
7	ENPVEE	8	GND
9	FPD 23	10	FPD 22
11	FPD 17	12	FPD 16
13	FPD 11	14	FPD 10
15	FPD 9	16	FPD 8
17	FPD 21	18	FPD 20
19	FPD 15	20	FPD 14
21	FPD 7	22	FPD 6
23	FPD 5	24	FPD 4
25	FPD 19	26	FPD 18
27	FPD 13	28	FPD 12
29	FPD 3	30	FPD 2
31	FPD 1	32	FPD 0
33	GND	34	GND
35	P_CLK	36	FLM
37	DE	38	LP
39	GND	40	PBKL
41	PNKL	42	KEY
43	VCC	44	VCC

USB PORT

Pin No.		Description
1	2	USB VCC
3	4	USB DATA-(0,1/2,3)
5	6	USB DATA+(0,1/2,3)
7	8	USB_GND
9	10	USB_GND

Audio Output Port Connector (CN1)

Pin No.	Function	Pin No.	Function
1	BITCLK	2	GND
3	SDIN	4	N.C.
5	SDIN2	6	N.C.
7	SDOUT	8	N.C.
9	SYNC	10	GND
11	-ACRST	12	GND
13	SPEAK	14	Strapping Low
15	+5V(DC)	16	+12V(DC)
17	JBCY	18	JAB2
19	JBCX	20	JAB1
21	JACY	22	JBB2
23	JACX	24	JBB1
25	MSO	26	MSI

IR Connector (J1)

Pin 1	VCC	Pin 4	GND
Pin 2	N.C	Pin 5	IRTX
Pin 3	IRRX		

IDE1, IDE2 Connector

Pin No.	Description	Pin No.	Description
2,19,22	GND	13	IDE data2
24,26,30	GND	14	IDE data13
40	GND	15	IDE data1
20,21,28	N.C	16	IDE data14
29,32,34	N.C	17	IDE data0
1	IDE reset	18	IDE data15
3	IDE data7	23	IDE Write
4	IDE data8	25	IDE Read
5	IDE data6	27	IDE Ready
6	IDE data9	31	IDE IRQ
7	IDE data5	33	IDE A1
8	IDE data10	35	IDE A0
9	IDE data4	36	IDE A2
10	IDE data11	37	IDECS1#
11	IDE data3	38	IDESC3#
12	IDE data12	39	HDLEDO#

Expansion Slot to PCI/ISA Pin Assignment

Pin No.	Description A	Description B	Description E	Description F
1	-IOCHK	GND	GND	GND
2	SD7	RSTDRV	GND	GND
3	SD6	VCC	-PCINT2	-PCINT4
4	SD5	IRQ9	-PCINT3	-PCINT1
5	SD4	-5V	VCC	VCC
6	SD3	DRQ2	KEY	KEY
7	SD2	-12V	VCC	VCC
8	SD1	0WS	-PCIRST	PCLKF
9	SD0	+12V	-GNT3	GND
10	IOCHRDY	GND	-REQ3	GNT1

Pin No.	Description A	Description B	Description E	Description F
11	AEN	-SMEMW	GND	GND
12	SA19	-SMEMR	PCLKE	-REQ1
13	SA18	-IOW	GND	AD31
14	SA17	-IOR	AD30	AD29
15	SA16	-DACK3	PCLKG	N.C
16	SA15	DRQ3	KEY	KEY
17	SA14	-DACK1	-GNT2	-REQ2
18	SA13	DRQ1	AD28	AD27
19	SA12	REFRESH	AD26	AD25
20	SA11	SYSCLK	AD24	-CBE3
21	SA10	IRQ7	AD22	AD23
22	SA9	IRQ6	AD20	AD21
23	SA8	IRQ5	AD18	AD19
24	SA7	IRQ4	N.C.	N.C
25	SA6	IRQ3	KEY	KEY
26	SA5	-DACK2	N.C	N.C
27	SA4	TC	AD16	AD17
28	SA3	BALE	-FRAME	-IRDY
29	SA2	VCC	-CBE2	-DEVSEL
30	SA1	OSC	-TRDY	-PLOCK
31	SA0	GND	-STOP	-PERR

Pin No.	Description C	Description D	Description G	Description H
1	-SBHE	-MEMCS16	N.C	-SERR
2	LA23	-IOSC16	N.C	AD15
3	LA22	IRQ10	-CBE1	AD14
4	LA21	IRQ11	PAR	AD12
5	LA20	IRQ12	GND	GND
6	LA19	IRQ13	KEY	KEY
7	LA18	IRQ14	GND	GND

Pin No.	Description C	Description D	Description G	Description H
8	LA17	-DACK0	AD13	AD10
9	-MEMR	DRQ0	AD11	AD8
10	-MEMW	-DACK5	AD9	AD7
11	SD8	DRQ5	-CBE0	AD5
12	SD9	-DACK6	AD6	AD3
13	SD10	DRQ6	AD4	AD1
14	SD11	-DACK7	AD2	AD0
15	SD12	DRQ7	KEY	KEY
16	SD13	VCC	VCC	VCC
17	SD14	MASTER	VCC	VCC
18	SD15	GND	GND	GND
19			GND	GND