

NAGASAKI IPC

IPC Solution

Website: <http://www.nagasaki.com.tw>

Email: [sales@nagasaki.com.tw](mailto:sales@nagasaki.com.tw)

## **PC104-688VL VIA Eden PC/ 104 CPU Board User's Manual**

---

Feb 2004  
Version: 1.0  
Part Number: PC104-  
688VI

## Copyright

©Copyright 2002 NAGASAKI IPC. The content of this publication may not be reproduced in any part or as a whole, transcribed, stored in a retrieval system, translated into any language, or transcribed in any form or by any means, electronic, mechanical, magnetic etc. or otherwise without the prior written permission of NAGASAKI IPC.

## Disclaimer

NAGASAKI makes no representation of warranties with respect to the contents of this publication. In an effort to continuously improve the product and add features, NAGASAKI reserves the right to revise the publication or change specifications contained in it from time to time without prior notice of any kind from time to time.

NAGASAKI shall not be reliable for technical or editorial errors or omissions, which may occur in this document. NAGASAKI shall not be reliable for any indirect, special, incidental or consequential damages resulting from the furnishing, performance, or use of this document.

## Trademarks

Trademarks, brand names and products names mentioned in this publication are used for identification purpose only and are the properties of their respective owners.

## Technical Support

If you have problems or difficulties in using the system board, or setting up the relevant devices, and software that are not explained in this manual, please contact our service engineer for service, or send email to [sales@nagasaki.com.tw](mailto:sales@nagasaki.com.tw).

## Returning Your Board For Service & Technical Support

If your board requires servicing, contact the dealer from whom you purchased the product for service information. You can help assure efficient servicing of your product by following these guidelines:

- ❑ A list of your name, address, telephone, facsimile number, or email address where you may be reached during the day
- ❑ Description of you peripheral attachments
- ❑ Description of you software (operating system, version, application software, etc.) and BIOS configuration
- ❑ Description of the symptoms (Extract wording any message)

For updated BIOS, drivers, manuals, or product information, please visit us at [www.nagasaki.com.tw](http://www.nagasaki.com.tw)

## Table of Content

<b>PC104-688VL VIA Eden PC/104 CPU Board User's Manual</b> .....	<b>i</b>
<b>Table of Content</b> .....	<b>iii</b>
<b>Chapter 1 Introducing the PC104-688VL System Board</b> .....	<b>1</b>
Overview.....	1
Layout.....	2
Specifications.....	3
Packing List .....	4
<b>Chapter 2 Hardware Installation</b> .....	<b>5</b>
Before Installation.....	5
Hardware Features .....	6
J8: Power Connector (4-pin 2.5mm JST) .....	7
J4: Reset Header.....	7
J3: RJ45 LAN /Adapter Connector with LED indicators.....	8
J2: Keyboard/Mouse Connector.....	9
J5: External Speaker Header .....	9
CN4: Audio Connector .....	10
CN8: USB Connector .....	10
FB4641: Provides Audio and USB Board.....	11
LED1: Power/Watchdog & J6: External HDD LED Header.....	11
CN7: IDE hard Disk Connectors.....	12
CN6: 26-pin Parallel Port Connector (26-pin 2.0mm IDC).....	13
CN2 & CN3: Serial Port Connectors RS-232C Pin Definitions .....	14
J7 & JP1: External Battery Header and Battery Select Jumper .....	15
JP1: Clear CMOS Data .....	15
BUS1: PC/104 Bus Connectors .....	16
DIMM1: So-DIMM Socket .....	17

<b>Chapter 3 Installing CRT</b> .....	<b>19</b>
CRT Display (CN5) .....	19
<b>Chapter 4 BIOS Setup</b> .....	<b>21</b>
Overview.....	21
BIOS Functions .....	22
Keyboard Convention.....	23
STANDARD CMOS SETUP .....	24
ADVANCED CMOS SETUP .....	26
ADVANCED CHIPSET SETUP .....	31
POWER MANAGEMENT .....	34
PCI/PLUG AND PLAY .....	36
PERIPHERAL SETUP.....	39
Hardware Monitor Setup .....	42
Password Setup .....	43
<b>Chapter 5 Driver and Utility</b> .....	<b>45</b>
VGA /Audio Driver for WIN98/WIN95.....	45
BIOS Flash Utility .....	46
LAN Utility .....	46
Watchdog Timer.....	47
Watchdog Timer Setting .....	48
Watchdog Timer Enabled.....	48
Watchdog Timer Trigger.....	48
Watchdog Timer Disabled .....	48
<b>Chapter 6 Technical Reference</b> .....	<b>49</b>
Trouble Shooting for Error Messages.....	49
Technical Reference .....	52
Real-Time Clock and Non-Volatile RAM .....	52
CMOS RAM Map .....	54
I/O Port Address Map .....	55
Interrupt Request Lines (IRQ) .....	56
DMA Channel Map.....	57
DMA Controller 2 .....	57
Serial Ports .....	58
Parallel Ports .....	62

**Appendix..... 65**  
Dimension ..... 65  
    PC104-688VL..... 錯誤! 尚未定義書籤。  
    FB4605 ..... 66  
    FB4641 ..... 66



## **Chapter 1 Introducing the PC104-688VL System Board**

### **Overview**

The PC104-688VL is a VIA Eden Low power processor, all in one, PC/104 CPU board. This user's manual provides information on the physical features, installation, and BIOS setup of the PC104-688VL.

Built to unleash the total potential of the VIA Eden Processor, the PC104-688VL is a single boards computer capable of handling today's demanding requirements. Able to support 400 MHz CPU, this unit supports 10/100M interface network port, synchronous pipeline burst SDRAM up to 512MB and a onboard VGA port up to 8MB share memory that can support CRT.

Each PC104-688VL has two ports for I/O communications. Two RS-232 ports are available. There is also a watchdog timer that can be configured from software to automatically reset the system. And for easy configuration, AMI BIOS are available.

Power management is also featured to lower the rate of consumption. The unit supports doze mode, <Suspend Mode> and <Standby mode> as well as it adheres to the "Green Function" standard.

The PC104-688VL is perfect for POS and POI applications, network systems, panel / MMI's, order entry kiosks, test equipment, OEM projects or as a motherboard for a panel PC. The unit is only 90.2x95.9mm, offering unparalleled performance in a very small footprint.



## Specifications

- Supports 300 ~ 733 MHz Low Power CPU. (400MHz for standard)
- VIA VT8601T+VT82C696B chipset and 64KB or above L2 cache inside the CPUs.
- One SoDIMM socket for up to 512MB PC-133 SDRAM.
- One 100M/10M Ethernet port.
- Onboard VGA port (VT8601T embedded) supports CRT up to 8MB shared memory.
- One parallel port, two RS-232, two USB, and One PCI IDE interface.
- PS/2 compatible keyboard and mouse interface.
- Provides header for external speaker and hard disk access LED.
- Software programmable watchdog timer.
- Provides cooling fan connector for monitoring.
- Provides One AC97 Audio function.
- Flash BIOS with easy upgrade utility.
- PC/104 form factor, 90.2 mm x 95.9 mm (3.55" x 3.775")
- Power requires +5V only, 2.2A maximum. (400MHz CPU)

## Packing List

Upon receiving the package, verify the following things. Should any of the mentioned happens, contact us for immediate service.

- Unpack and inspect the PC104-688VL package for possible damage that may occur during the delivery process.
- Verify the accessories in the package according to the packing list and see if there is anything missing or incorrect package is included.
- If the cable(s) you use to install the PC104-688VL is not supplied from us, please make sure the specification of the cable(s) is compatible with the PC104-688VL system board.

**Note:** after you install the PC104-688VL, it is recommended that you keep the diskette or CD that contains drivers and document files, document copies, and unused cables in the carton for future use.

The following lists the accessories that may be included in your PC104-688VL package. Some accessories are optional items that are only shipped upon order.

- One PC104-688VL All-In-One PC/104 CPU board
- One VGA (CRT interface) adapter cable
- One 44-pin hard disk drive interface cable
- Two serial port and parallel port interface cable
- One PS2 keyboard and mouse port adapter cable
- One 10-pin LAN adapter cable with FB4605A board.
- One USB cable, One Audio cable, and one FB4641 Audio/USB adapter board.
- One compact disc containing manual file in PDF format and necessary drivers and utilities
- One hard copy of Quick Installation Guide

## Chapter 2 Hardware Installation

To set up a PC104-688VL system board, complete the description Chapter 2 and Chapter 3.

This chapter introduces the system board connectors, jumper settings and then guides you to apply them for field application.

### Before Installation

Before you install the system board, make sure you follow the following descriptions.

1. Before removing the board from its anti-static bag, wear an anti-static strap to prevent the generation of Electricity Static Discharge (ESD). The ESD may be created from human body that touches the board. It may do damage to the board circuit.
2. Install or unplug any connector, module, or add-on card, be sure that the power is disconnected from the system board. If not, this may damage the system board components, module, or the add-on-card.
3. Installing a heat sink and cooling fan is necessary for heat dissipation from your CPU. If heat sink or cooling fan is not mounted, this may cause the CPU fail due to over-heating problem.
4. When you connect the connectors and memory modules, be careful with the pin orientations.

## Hardware Features

The following lists the connectors and jumpers to install the PC104-688VL.

Item	Description
CN1	LCD Connector with 24 bit TTL signals (Reserved for VIA8606)
CN2, CN3	10-pin RS-232 port connector
CN4, CN8	Connector to daughter board FB4641, provides AC97 signals for Audio and USB
CN5	10-pin CRT connector
CN6	26-pin 2.0mm parallel port connector
CN7	44-pin 2.0mm IDE 2 hard disk connector
J1	3-pin for case/CPU cooling fan
J2	5-pin for Keyboard and Mouse connector
J3	10-pin for RJ45-Lan connector
J4	2-pin Reset header
J5	2-pin for external speaker header
J6	2-pin for HDD LED indicator
J7	2-pin External battery header
J8	4-pin Power connector
JP1	3-pin Battery Select /Clean CMOS jumper
LED1	Power and watchdog of LED indicator

□ **J8: Power Connector (4-pin 2.5mm JST)**

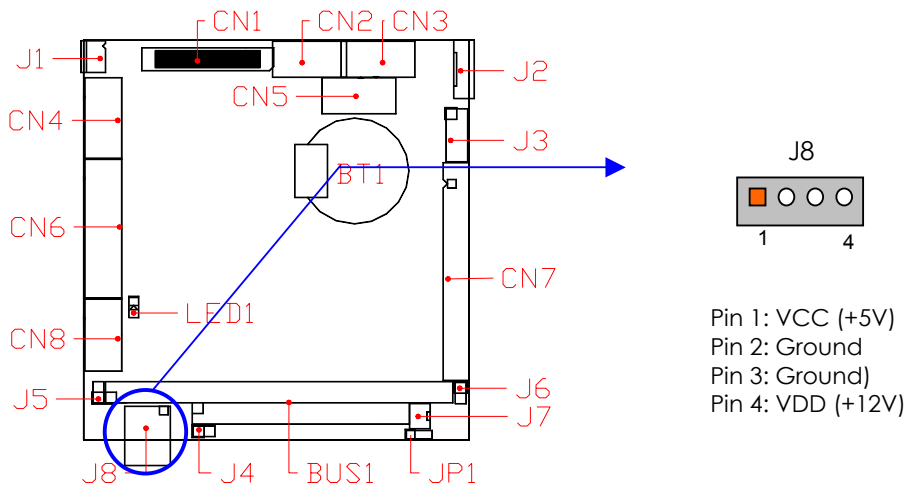

□ **J4: Reset Header**

J4 is a 2-pin header for connecting to system reset bottom. Short-circuit these 2 pins to hardware reset PC104-688VL as well as restart system. It is similar to power off the system and then power it on again.

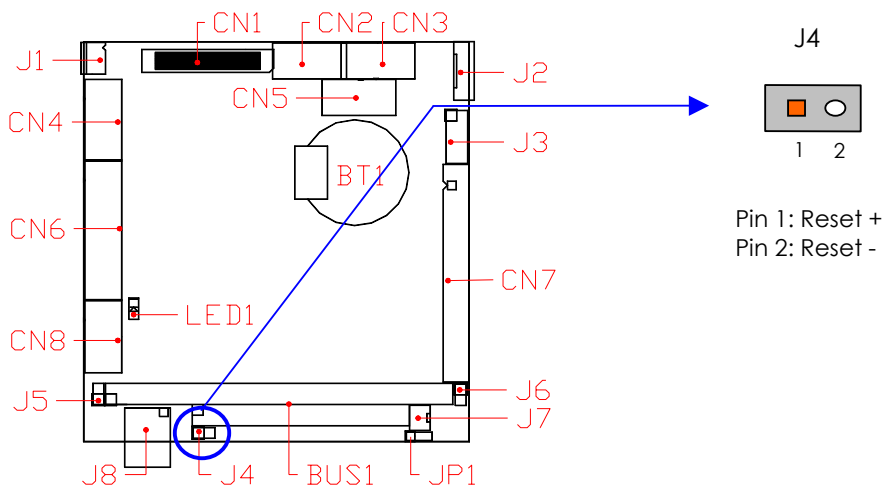

□ **J3: RJ45 LAN /Adapter Connector with LED indicators**

FB4605A is a RJ45 connector with 2 LEDs for LAN. The left side LED (orange) indicates data is being accessed and the right side LED (green) indicates on-line status. (On indicates on-line and off indicates off-line) J3 provide twist-pair signals of LAN port if you got LAN version and adapter board (FB4605A) with cable. The following table lists the pin assignments of J3 to RJ45 connector on the FB4605A LAN adapter board:

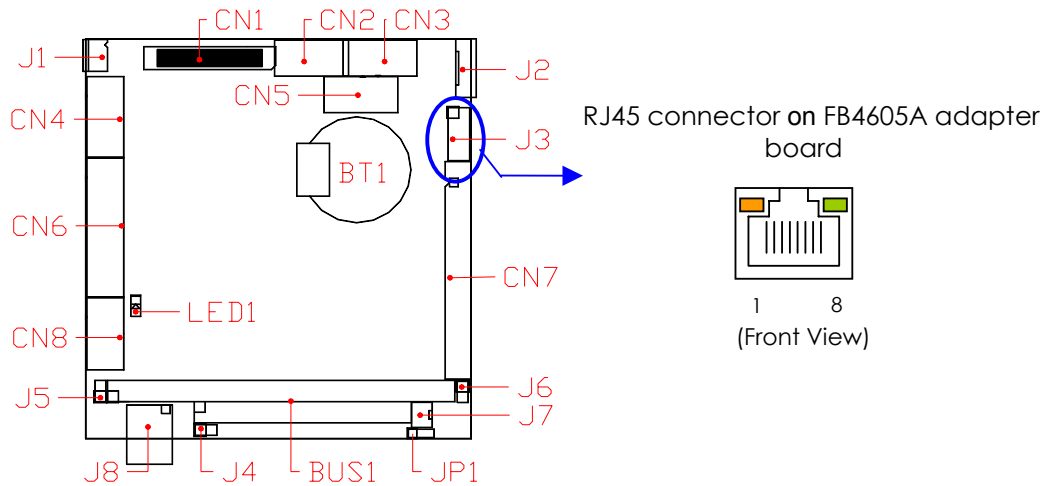

The following lists the pin assignment of J3.

J3	Signal	RJ45	J3	Signal	RJ45
1	TPTX+	1	6	Access LED	-
2	TPTX -	2	7	On-Line LED	-
3	TPRX+	3	8	Case GND	-
4	TPRX -	6	9	FBG1	4
5	LED Common	-		FBG1	5
				FBG2	7
			10	FBG2	8

□ **J2: Keyboard/Mouse Connector**

J2 is a 6-pin 2.0mm JST connector, use the included adapter cable you can attach standard PS/2 type keyboard and mouse.

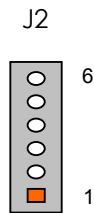
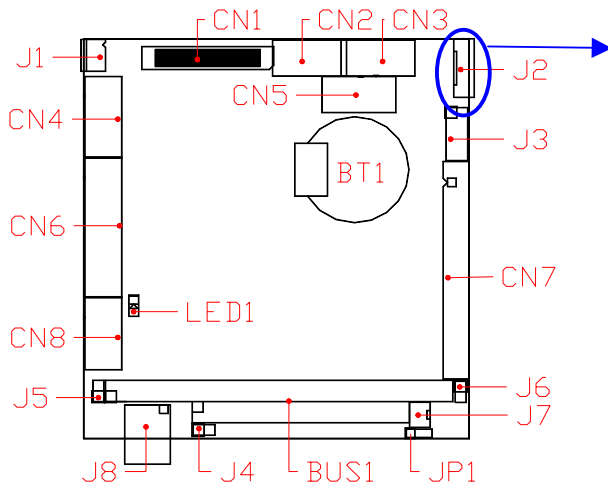

- Pin 1: Mouse Data
- Pin 2: Keyboard Data
- Pin 3: Ground
- Pin 4: VCC
- Pin 5: Mouse Clock
- Pin 6: Keyboard Clock

□ **J5: External Speaker Header**

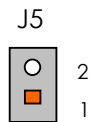
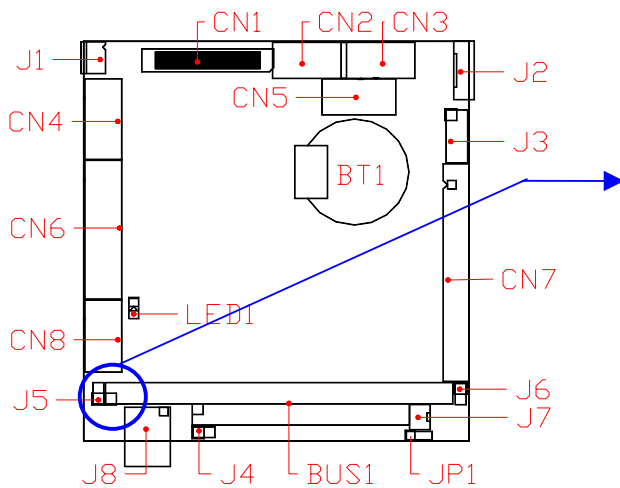

PIN	Signal
1	Speaker+
2	Speaker-

□ **CN4: Audio Connector**

CN4 is a 12-pin 2.0mm IDC connector with AC97 signals for Audio I/O. Use the included Audio cable and FB4641 adapter board for your Audio applications.

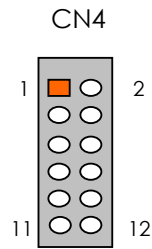
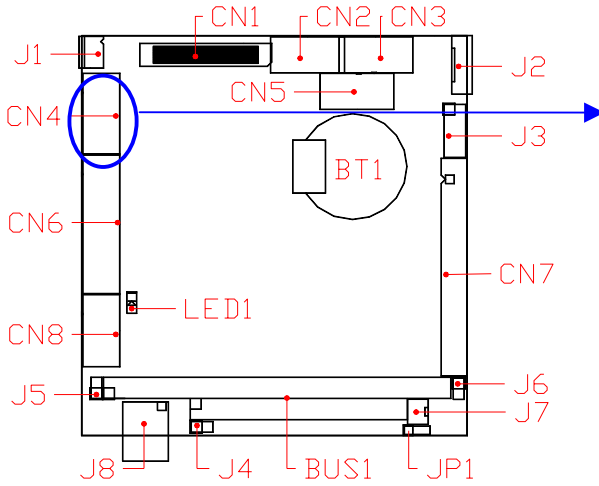

CN4	Description	CN4	Description
1	BITCLK	2	+12v
3	+5V	4	SYNC
5	Ground	6	Ground
7	+3.3V	8	ACRST#
9	SDOUT	10	SPKR
11	SDIN	12	SDIN2

□ **CN8: USB Connector**

Use the USB adapter cable and FB4641 board, you can attach up to 2 USB devices.

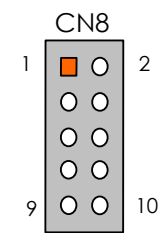
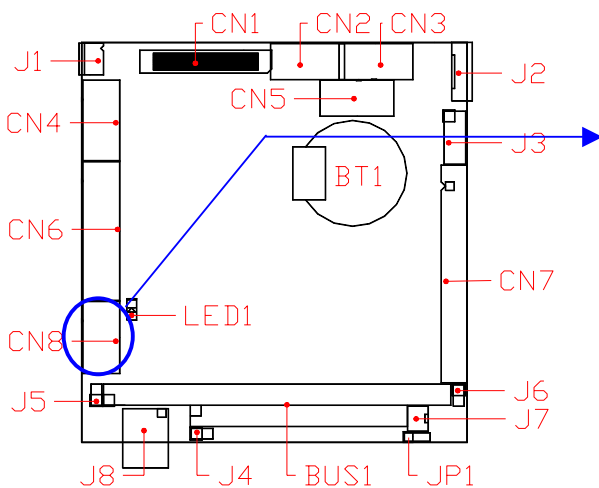

Pin 1:	USBV0	Pin2:	Case Ground
Pin 3:	USB0 -	Pin4:	USBG1
Pin 5:	USB0+	Pin6:	USB1+
Pin 7:	USB0	Pin8:	USB1-
Pin9:	Case Ground	Pin10:	USBV1

□ **FB4641: Provides Audio and USB Board**

The J3, J4, and J5 connectors on FB4641 are 2-way Line-In, mono Microphone input, and 2-way Lineout respectively. You can connect connectors J1, CN2 cable from PC104-688VL CN4 and CN8. The following figure shows these Audio connectors on FB4641 board:

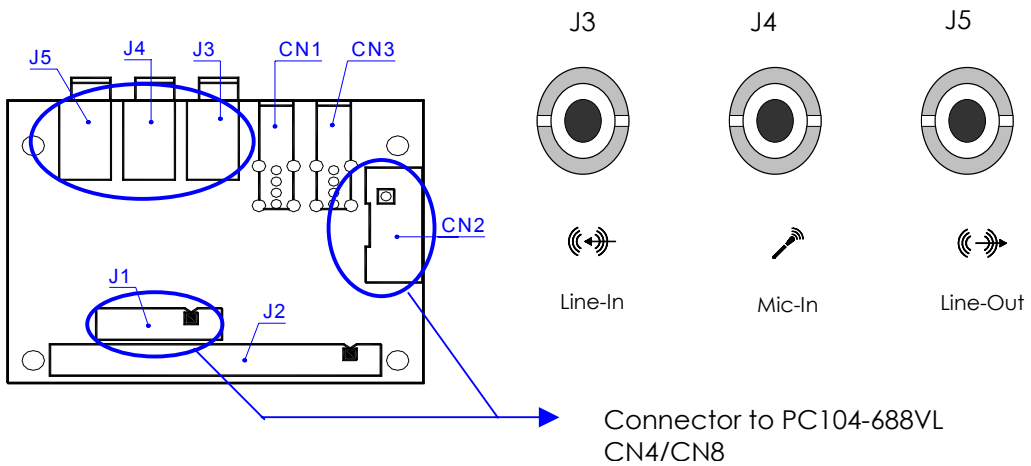

□ **LED1: Power/Watchdog & J6: External HDD LED Header**

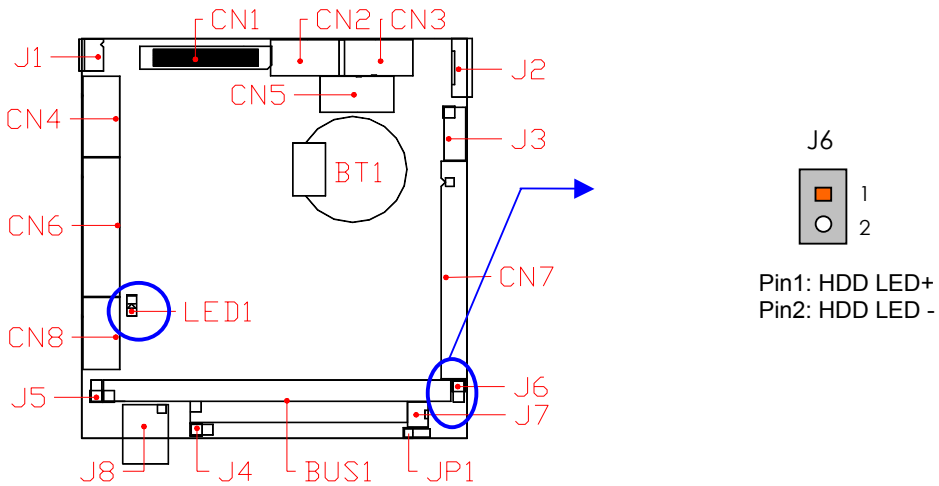

□ **CN7: IDE hard Disk Connectors**

CN7 is 44-pin 2.0mm IDC connectors. Use the included hard disk cables to attach up to two 2.5" hard disk drives.

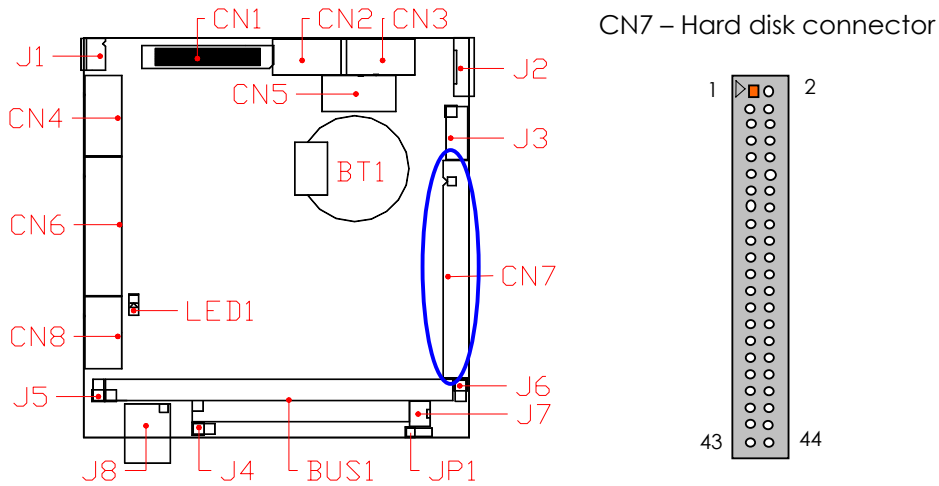

The following table lists the pin description of CN7.

Pin	Description	Pin	Description
1	-RESET	2	GROUND
3	DATA 7	4	DATA 8
5	DATA 6	6	DATA 9
7	DATA 5	8	DATA 10
9	DATA 4	10	DATA 11
11	DATA 3	12	DATA 12
13	DATA 2	14	DATA 13
15	DATA 1	16	DATA 14
17	DATA 0	18	DATA 15
19	GROUND	20	NOT USED
21	IDEDREQ	22	GROUND
23	-IOW A	24	GROUND
25	-IOR A	26	GROUND
27	IDEIORDYA	28	GROUND
29	-DACKA	30	GROUND
31	AINT	32	GROUND
33	SA 1	34	Not Used
35	SA 0	36	SA 2
37	CS 0	38	CS 1
39	HD LED A	40	GROUND
41	VCC	42	VCC
43	GROUND	44	Not Used

□ **CN6: 26-pin Parallel Port Connector (26-pin 2.0mm IDC)**

The included printer interface cable is used to transfer 26-pin connector into standard DB25 connector.

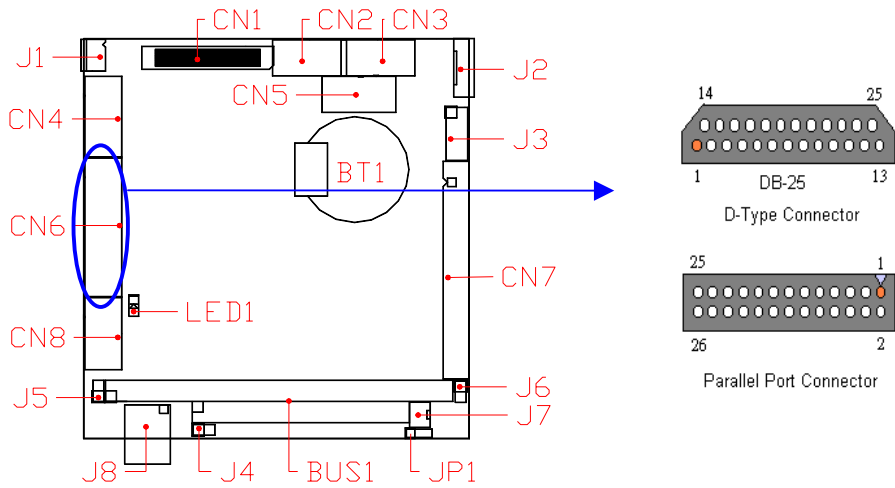

CN6	DB-25	Description	CN6	DB-25	Description
1	1	-STROBE	2	14	-AUTO FORM FEED
3	2	DATA 0	4	15	-ERROR
5	3	DATA 1	6	16	-INITIALIZE
7	4	DATA 2	8	17	-PRINTER SELECT IN
9	5	DATA 3	10	18	Ground
11	6	DATA 4	12	19	Ground
13	7	DATA 5	14	20	Ground
15	8	DATA 6	16	21	Ground
17	9	DATA 7	18	22	Ground
19	10	-ACKNOWLEDGE	20	23	Ground
21	11	BUSY	22	24	Ground
23	12	PAPER	24	25	Ground
25	13	PRINTER SELECT	26	--	No Used

□ **CN2 & CN3: Serial Port Connectors RS-232C Pin Definitions**

CN2 (COM1) & CN3 (COM2) are 10-pin 2.0mm IDC connectors. The included serial port adapter cables are used to transfer 10-pin 2.0mm IDC into standard DB-9 connector. The following tables show the signal connections of these connectors and the included adapter cable for CN2 & CN3:

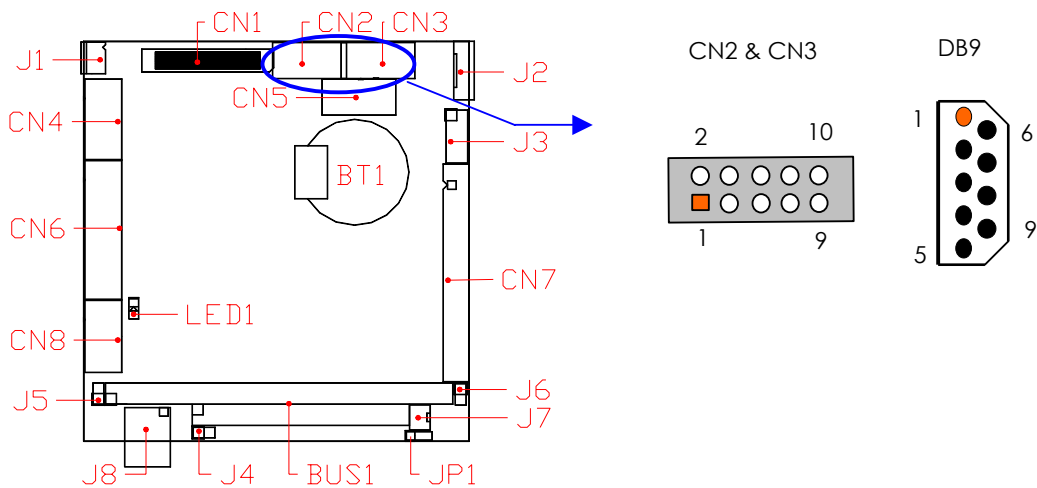

CN2 & CN3	RS-232 Signal	DB9
1	-DCD2	1
2	-DSR2	6
3	RXD2	2
4	-RTS2	7
5	-TXD2	3
6	-CTS2	8
7	-DTR2	4
8	-RI2	9
9	GROUND	5
10	GROUND	Shield

□ **J7 & JP1: External Battery Header and Battery Select Jumper**

J7 is used to connect an external battery pack if on-board Lithium battery is empty or not and please setting JP1 properly of on-board battery or external battery.

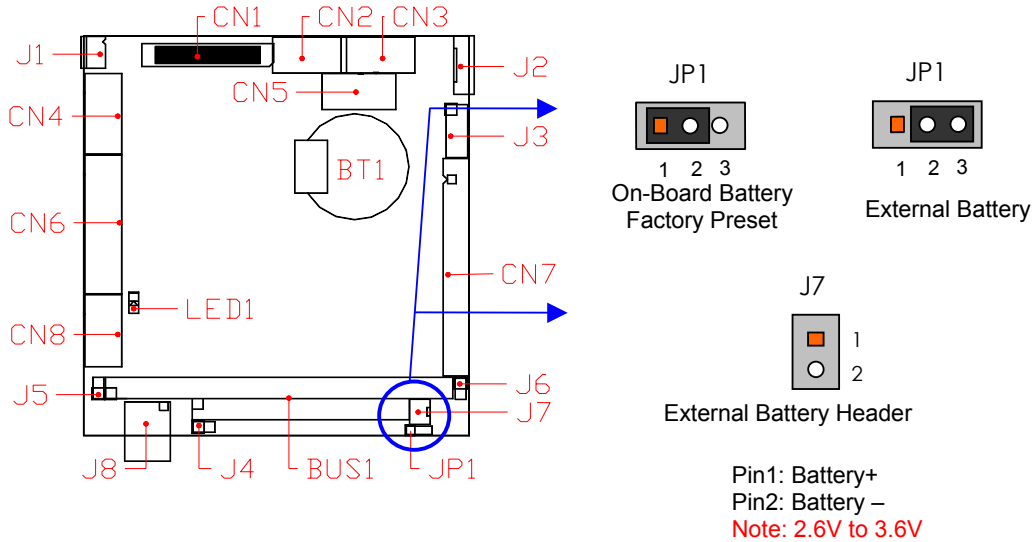

□ **JP1: Clear CMOS Data**

You can use JP1 to clear CMOS data. The CMOS store information like system date, time, boot up device, password, IRQ... that are set up with the BIOS. To clear the CMOS, set JP1 to open then return to 1-2 before system is power -off. The default setting is 1-2.

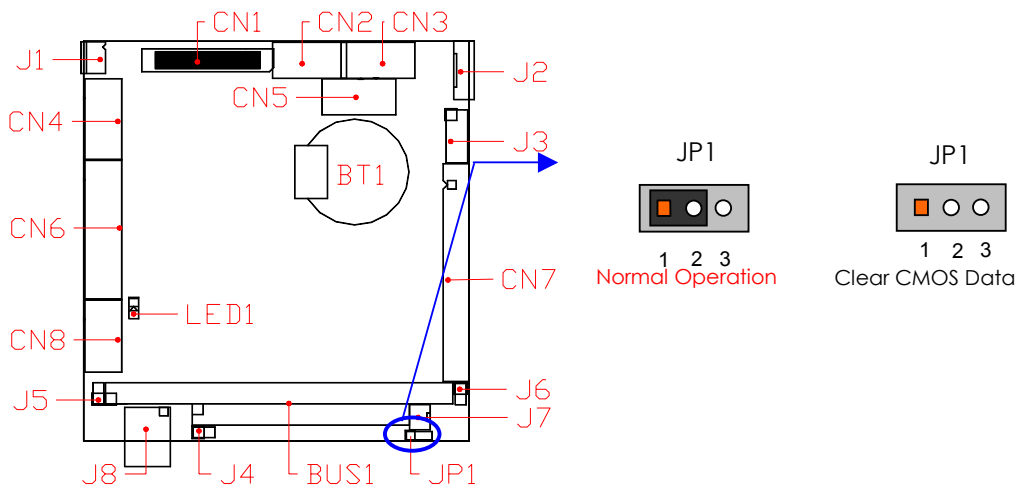

□ **BUS1: PC/104 Bus Connectors**

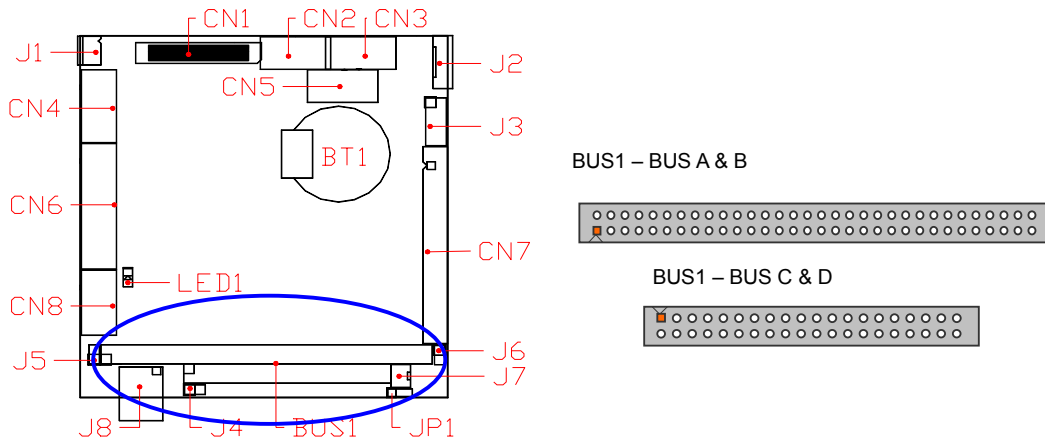

**PC/104 A&B Pin**

Pin	Signal	Pin	Signal	Pin	Signal	Pin	Signal
A1	-IOCHK	A17	SA14	B1	Ground	B17	-DACK1
A2	SD7	A18	SA13	B2	RSTDRV	B18	DRQ1
A3	SD6	A19	SA12	B3	+5V	B19	-Refresh
A4	SD5	A20	SA11	B4	IRQ9	B20	BUSCLK
A5	SD4	A21	SA10	B5	--	B21	IRQ7
A6	SD3	A22	SA9	B6	DRQ2	B22	IRQ6
A7	SD2	A23	SA8	B7	--	B23	IRQ5
A8	SD1	A24	SA7	B8	-ZWS	B24	IRQ4
A9	SD0	A25	SA6	B9	+12V	B25	IRQ3
A10	IORDY	A26	SA5	B10	KEY	B26	-DACK2
A11	AEN	A27	SA4	B11	-SMEMW	B27	TC
A12	SA19	A28	SA3	B12	-SMEMR	B28	ALE
A13	SA18	A29	SA2	B13	-IOW	B29	+5V
A14	SA17	A30	SA1	B14	-IOR	B30	OSC
A15	SA16	A31	SA0	B15	-DACK3	B31	Ground
A16	SA15	A32	Ground	B16	DRQ3	B32	Ground

**PC/104 C& D Pin**

Pin	Signal	Pin	Signal	Pin	Signal	Pin	Signal
C1	GND	C11	MEMW#	D1	Ground	D11	-DACK#5
C2	SBHE	C12	SD8	D2	MEMCS16#	D12	DREQ5
C3	LA23	C13	SD9	D3	IOCS16#	D13	DACK#6
C4	LA22	C24	SD10	D4	IRQ10	D14	DREQ6
C5	LA21	C25	SD11	D5	IRQ11	D15	DACK#7
C6	LA20	C26	SD12	D6	IRQ12	D16	DREQ7
C7	LA19	C27	SD13	D7	IRQ15	D17	VCC
C8	LA18	C28	SD14	D8	IRQ14	D18	-
C9	LA17	C29	SD15	D9	DACK#0	D19	GND
C10	MEMR#	C20	KEY	D10	DREQ0	D20	GND

□ **DIMM1: So-DIMM Socket**

The DIMM1 socket on the solder side accepts 32MB to 512MB PC-100 SDRAM modules.

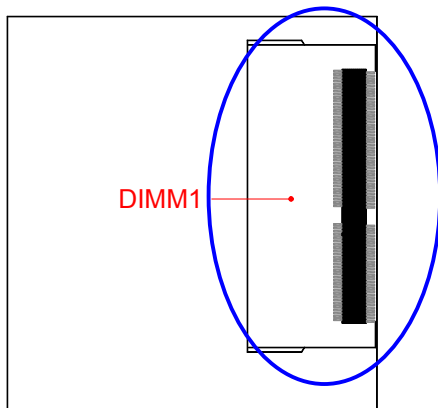



## Chapter 3 Installing CRT

This chapter describes the configuration and installation procedure CRT display.

### CRT Display (CN5)

The PC104-688VL supports a CRT colored monitor. It can be connected to create a compact video solution for the industrial environment. 8MB simulated VRAM allows a maximum CRT resolution of 1280X1024 with 64K colors. The following table and figure illustrate the pin definition of CN5 and D-sub 15-pin on the CRT adapter cable:

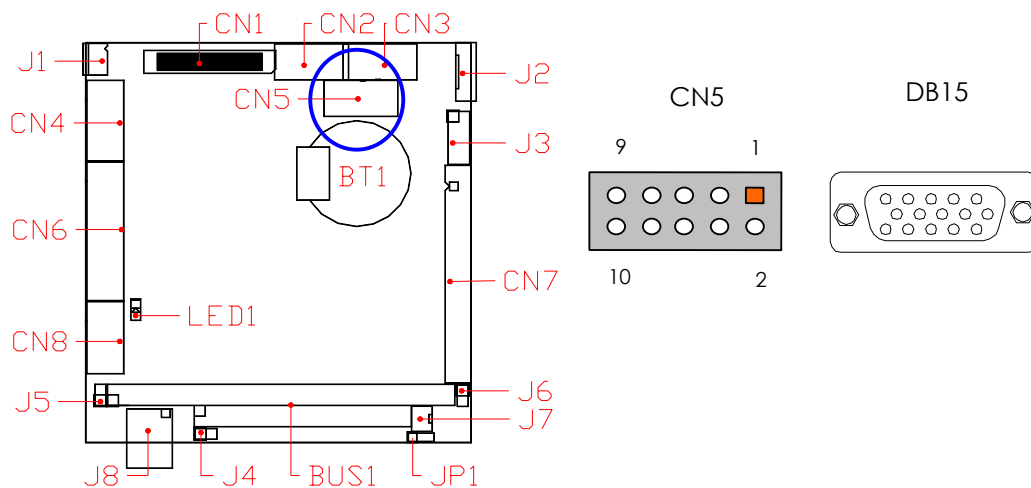

CN5	Signal	DB-15	CN5	Signal	DB15
1	RED	1	2	Case Ground	Case
3	GREEN	2	4	Digital Ground	5,10
5	BLUE	3	6	Analog Ground	6,7,8
7	VSYNC	14	8	DDC Data	12
9	HSYNC	13	10	DDC Clock	15

**NOTE:** Be careful with the pin orientation when installing VGA connector and the cable.



## Chapter 4 BIOS Setup

This chapter describes the BIOS setup.

### Overview

BIOS are a program located on a Flash memory chip on a circuit board. It is used to initialize and set up the I/O peripherals and interface cards of the system, which includes time, date, hard disk drive, the PCI bus and connected devices such as the video display, diskette drive, and the keyboard. This program will not be lost when you turn off the system.

The BIOS provides a menu-driven interface to the console subsystem. The console subsystem contains special software, called firmware that interacts directly with the hardware components and facilitates interaction between the system hardware and the operating system.

The BIOS default values ensure that the system will function at its normal capability. In the worst situation, the user may have corrupted the original settings set by the manufacturer.

All the changes you make will be saved in the system RAM and will not be lost after power-off.

When you start the system, the BIOS will perform a self-diagnostics test called Power on Self Test (POST) for all the attached devices, accessories, and the system. Press the [Del] key to enter the BIOS Setup program, and then the main menu will show on the screen.

**Note:** Change the parameters when you fully understand their functions and subsequence.

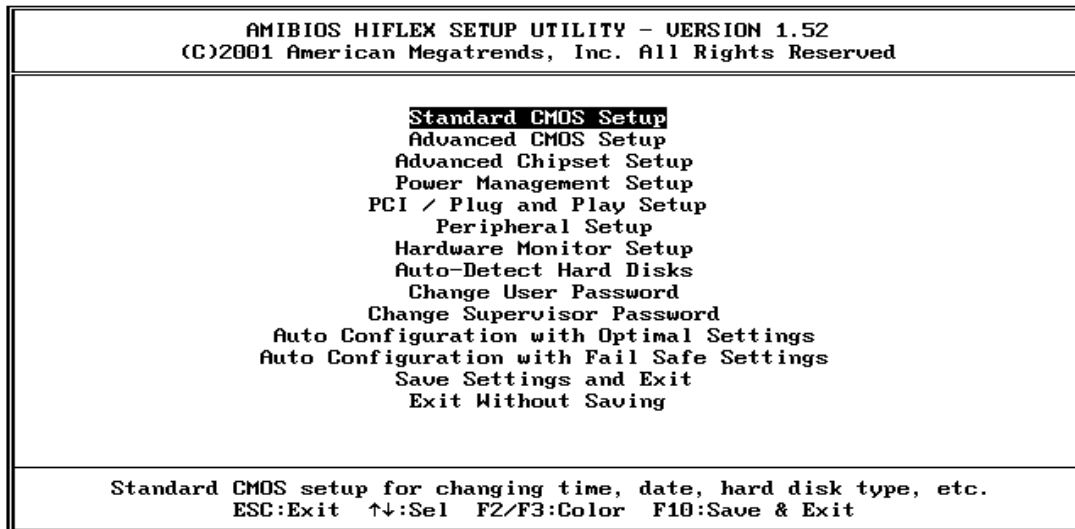

## BIOS Functions

On the menu, you can perform the following functions

1. Standard CMOS Setup
2. Advanced CMOS Setup
3. Advanced Chipset Setup
4. Power Management Setup
5. PCI/ Plug and Play Setup
6. Peripheral Setup
7. Hardware Monitor Setup
8. Auto-Detect Hard Disks
9. Change User Password
10. Change Supervisor Password
11. Auto Configuration with Optimal Settings: to auto configure the system according to optimal setting with pre-defined values. This is also the factory default setting of the system when you receive the board.
12. Auto Configuration with Fail Safe Settings: to configure the system in fail-safe mode with predefined values.
13. Save Settings and Exit: perform this function when you change the setting and exit the BIOS Setup program.
14. Exit without saving: perform this function when you want to exit the program and do not save the change.

**Keyboard Convention**

On the BIOS, the following keys can be used to operate and manage the menu:

Item	Function
ESC	To exit the current menu or message
Page Up/Page Down	To select a parameter
F1	To display the help menu if you do not know the purpose or function of the item you are going to configure
F2/F3	To change the color of the menu display. F2 is to go forward and F3 is to go backward.
UP/Down Arrow Keys	To go upward or downward to the desired item

## STANDARD CMOS SETUP

This section describes basic system hardware configuration, system clock setup and error handling. If the CPU board is already installed in a working system, you will not need to select this option anymore.

AMIBIOS SETUP - STANDARD CMOS SETUP									
(C)2001 American Megatrends, Inc. All Rights Reserved									
Date (mm/dd/yyyy): Fri <b>Dec</b> 12,2003					Base Memory: 0 KB				
Time (hh/mm/ss) : 16:03:48					Extd Memory: 0 MB				
Floppy Drive A: Not Installed									
Floppy Drive B: Not Installed									
	Type	Size	Cyln	Head	WPcom	Sec	LBA Mode	Blk Mode	PIO 32Bit Mode
Pri Master:	Auto								On
Pri Slave :	Auto								On
Sec Master:	Not Installed								
Sec Slave :	Not Installed								
Boot Sector Virus Protection					Disabled				
Month:	Jan - Dec				ESC:Exit ↑↓:Sel				
Day:	01 - 31				PgUp/PgDn:Modify				
Year:	1980 - 2099				F1:Help F2/F3:Color				

### □ Date & Time Setup

Highlight the <Date> field and then press the [Page Up] / [Page Down] or [+]/[-] keys to set the current date. Follow the month, day and year format.

Highlight the <Time> field and then press the [Page Up] / [Page Down] or [+]/[-] keys to set the current date. Follow the hour, minute and second format.

The user can bypass the date and time prompts by creating an AUTOEXEC.BAT file. For information on how to create this file, please refer to the MS-DOS manual.

### □ Hard Disk Setup

The BIOS supports various types for user settings, The BIOS supports <Pri Master>, <Pri Slave>, <Sec Master> and <Sec Slave> so the user can install up to four hard disks. For the master and slave jumpers, please refer to the hard disk's installation descriptions and the hard disk jumper settings.

You can select <AUTO> under the <TYPE> and <MODE> fields. This will enable auto detection of your IDE drives during boot up. This will allow you to change your hard drives (with the power off) and then power on without having to reconfigure your hard drive type. If you use older hard disk drives, which do not support this feature, then you must configure the hard disk drive in the standard method as described above by the <USER> option.

□ **Boot Sector Virus Protection**

This option protects the boot sector and partition table of your hard disk against accidental modifications. Any attempt to write to them will cause the system to halt and display a warning message. If this occurs, you can either allow the operation to continue or use a bootable virus-free floppy disk to reboot and investigate your system. The default setting is <**Disabled**>. This setting is recommended because it conflicts with new operating systems. Installation of new operating system requires that you disable this to prevent write errors.

## ADVANCED CMOS SETUP

AMIBIOS SETUP - ADVANCED CMOS SETUP (C)2001 American Megatrends, Inc. All Rights Reserved		
Quick Boot	Enabled	<b>Available Options:</b> ▶ Disabled Enabled  ESC:Exit   ↑↓:Sel PgUp/PgDn:Modify F1:Help   F2/F3:Color
1st Boot Device	IDE-0	
2nd Boot Device	Floppy	
3rd Boot Device	CD/DVD	
Try Other Boot Devices	Yes	
Hard Disk Access Control	Read-Write	
<b>S.M.A.R.T. for Hard Disks</b>	<b>Disabled</b>	
BootUp Num-Lock	On	
Floppy Drive Swap	Disabled	
Floppy Drive Seek	Disabled	
PS/2 Mouse Support	Enabled	
System Keyboard	Absent	
Primary Display	Absent	
Password Check	Setup	
Boot To OS/2	No	
Wait For 'F1' If Error	Disabled	
Hit 'DEL' Message Display	Enabled	
L1 Cache	Enabled	
L2 Cache	Enabled	
C000,32k Shadow	Cached	
C800,16k Shadow	Cached	
CC00,16k Shadow	Disabled	
D000,16k Shadow	Disabled	
D400,16k Shadow	Disabled	
D800,16k Shadow	Disabled	
DC00,16k Shadow	Disabled	

This section describes the configuration entries that allow you to improve your system performance, or let you set up some system features according to your preference. Some entries here are required by the CPU board's design to remain in their default settings.

### ❑ Quick Boot

This field is used to activate the quick boot function of the system. When set to Enabled,

1. BIOS will not wait for up to 40 seconds if a Ready signal is not received from the IDE drive, and will not configure its drive.
2. BIOS will not wait for 0.5 seconds after sending a RESET signal to the IDE drive.
3. You cannot run BIOS Setup at system boot since there is no delay for the Hit, Del. To run Setup message.

**Available Options:** Disabled, Enabled

**Default setting:** Enabled

### ❑ 1st -3rd Boot Device

These fields determine where the system attempts to look for the boot drive priority for an operating system. The default procedure is to check the hard disk, and then the floppy drive, and last the CDROM.

**Available options:** Disabled, IDE0-1, IDE-2, IDE-3, Floppy, ARMD-FDD, ARMD-HDD, CD/DVD, USB-FLOPPY, USB-CDROM, USB-HDD and SCSI, Network

**Default setting:** IDE-0 for 1<sup>st</sup> Boot device; Floppy for 2<sup>nd</sup> Boot Device; CDROM for 3<sup>rd</sup> Boot Device

**Try Other Boot Device**

If all 3 1<sup>st</sup>–3<sup>rd</sup> boot devices specified by CMOS setup are not available to boot, BIOS will try to boot other available devices in following order if this question is set to "Enabled".

**Initial Display Mode**

This field specifies can set Normal POST screen (BIOS) or Boot with logo, no POST messages (Client).

**Floppy Access Control**

This field specifies the read/write access when booting from a floppy drive.

**Available options:** Normal, Read-only

**Default setting:** Normal

**Hard Disk Access Control**

This field specifies the read/write access when booting from a HDD drive.

**Available options:** Normal, Read-only

**Default setting:** Normal

**S.M.A.R.T for Hard Disk**

This field is used to activate the S.M.A.R.T (System Management and Reporting Technologies) function for S.M.A.R.T HDD drives. This function requires an application that can give S.M.A.R.T message.

**Available options:** Disabled, Enabled

**Default:** Disabled

**Boot Up Num-lock**

This field is used to activate the Num Lock function upon system boot. If the setting is on, after a boot, the Num Lock light is lit, and user can use the number key.

**Available options:** On, Off

**Default setting:** On

#### **Floppy Drive Swap**

The field reverses the drive letter assignments of your floppy disk drives in the Swap A, B setting, otherwise leave on the default setting of **Disabled** (No Swap). This works separately from the BIOS Features floppy disk swap feature. It is functionally the same as physically interchanging the connectors of the floppy disk drives. When the function's setting is **<Enabled>**, the BIOS swapped floppy drive assignments so that Drive A becomes Drive B, and Drive B becomes Drive A under DOS.

**Available options:** Disabled, Enabled

**Default setting:** Disabled

#### **Floppy Drive Seek**

This field is used to set if the BIOS will seek the floppy <A> drive upon boot.

**Available Options:** Disabled, Enabled

**Default setting:** Disabled

#### **PS/2 Mouse Support**

The setting of **Enabled** allows the system to detect a PS/2 mouse on boot up. If detected, IRQ12 will be used for the PS/2 mouse. IRQ 12 will be reserved for expansion cards if a PS/2 mouse is not detected. **Disabled** will reserve IRQ12 for expansion cards and therefore the PS/2 mouse will not function.

**Available options:** Disabled, Enabled

**Default setting:** Enable

#### **System Keyboard**

This field specifies if an error message should be prompted when a keyboard is not attached.

**Available options:** Absent, Present

**Default setting:** Absent

#### **Primary Display**

The field specifies the type of monitor installed in the system.

**Available options:** Absent, VGA/EGA, CGA40x25, CGA80x25, and Mono

**Default setting:** Absent

**Password Check**

This field enables password checking every time the computer is powered on or every time the BIOS Setup is executed. If **Always** is chosen, a user password prompt appears every time and the BIOS Setup Program executes and the computer is turned on. If **Setup** is chosen, the password prompt appears if the BIOS executed.

**Available options:** Setup, Always

**Default setting:** Setup

 **Boot To OS2**

If OS2 operating system is used, and the system RAM is over 64MB, please select yes. Otherwise, select No.

**Available options:** Yes, No

**Default setting:** No

 **Wait for 'F1' If Error**

AMIBIOS POST error messages are followed by:

Press <F1> to continue

If this field is set to **Disabled**, the AMIBIOS does not wait for you to press the <F1> key after an error message.

**Available options:** Disabled, Enabled

**Default setting:** Disabled

 **Hit 'DEL' Message Display**

Set this field to **Disabled** to prevent the message as follows:

Hit 'DEL' if you want to run setup

It will prevent the message from appearing on the first BIOS screen when the computer boots.

**Available options:** Disabled, Enabled

**Default setting:** Enabled

□ **C000, 32k Shadow - E800, 32k shadow**

These fields control the location of the contents of the 32KB of ROM beginning at the specified memory location. If no adapter ROM is using the named ROM area, this area is made available to the local bus. The settings are:

1. **Disabled:** The video ROM is not copied to RAM. The contents of the video ROM cannot be read from or written to cache memory.
2. **Enabled:** The contents of C000h - C7FFFh are written to the same address in system memory (RAM) for faster execution.
3. **Cached/WP:** The contents of the named ROM area are written to the same address in system memory (RAM) for faster execution, if an adapter ROM will be using the named ROM area. Also, the contents of the RAM area can be read from and written to cache memory.

**Available options:** Disabled, Enabled, Cached

**Default setting:** Disabled

**Default setting:** Disable

## ADVANCED CHIPSET SETUP

This section describes the configuration of the board's chipset features.

AMIBIOS SETUP - ADVANCED CHIPSET SETUP (C)2001 American Megatrends, Inc. All Rights Reserved		
***** DRAM Timing *****		
<b>Configure SDRAM Timing by SPD</b>	<b>Disabled</b>	Available Options: ▶ Disabled Enabled
DRAM Frequency	100Mhz	
SDRAM CAS# Latency	3	
AGP Mode	4x	
AGP Aperture Size	64MB	
ISA Bus Clock	PCICLK/4	
USB Controller	Enabled	
USB Device Legacy Support	All Device	
OnChip VGA Frame Buffer Size	2MB	
ESC:Exit ↑↓:Sel PgUp/PgDn:Modify F1:Help F2/F3:Color		

**Configure SDRAM Timing by SPD**

SPD represents Serial Presence Detect. It is an 8-bit, 2048 bits EEPROM, built on the SDRAM for 100 MHz frequencies. If the installed SDRAM supports SPD function, select SPD. If not, you can select based on other access time of the SDRAM.

**Available Options:** Disabled, Enabled

**Default setting:** Disabled

**DRAM Frequency**

This specifies the SDRAM memory clock frequency.

**Available Options:** 100MHz, 133MHz

**Default setting:** 100MHz

**SDRAM CAS# Latency (SCLKs)**

This field specifies the latency for the Synchronous DRAM system memory signals.

**Available Options:** 3, 2

**Default setting:** 3

**ISA Bus Clock**

This field sets the polling clock speed of ISA Bus (PC/104).

**Available Options:** PCICLK/2, PCICLK/3, PCICLK/4, PCICLK/5 and PCICLK/6

**Default setting:** PCICLK/4

**NOTE:** 1. PCICLK means the PCI BUS inputs clock (33Mhz).  
2. User is recommended to use setting at the range of 8MHz to 10MHz.

**AGP Mode**

This field select AGP transfers video data.

**Available Options:** 1x, 2x and 4x

**Default setting:** 4x

**AGP Aperture Size**

This field specifies the system memory size that can be used by the Accelerated Graphics Port (AGP).

**Available Options:** 4MB, 8MB, 16MB, 32MB, 64MB, 128MB and 256MB

**Default setting:** 64 MB

**USB Control**

Select Enabled if a USB device is installed to the system. If Disabled are selected, the system will not be able to use a USB device.

**Available Options:** Disabled, Enabled

**Default setting:** Enabled

**USB Device Legacy Support**

Select All Device if a USB device is installed to the system. If Disabled are selected, the system will not be able to use a USB device.

**Available Options:** Disabled, All Device

**Default setting:** All Device

□ **OnChip VGA Frame Buffers Size**

This field is share memory architecture (SMA) for frame buffer memory. SMA allows system memory to be efficiently share by the host CPU and allocated depending on user preference, application requirements, and total size of system memory.

**Available Options:** None, 2MB, 4MB and 8MB

**Default setting:** 2 MB

## POWER MANAGEMENT

AMIBIOS SETUP - POWER MANAGEMENT SETUP (C)2001 American Megatrends, Inc. All Rights Reserved		
<b>Power Management/APM</b>	<b>Enabled</b>	<b>Available Options:</b>
Video Power Down Mode	Disabled	Disabled
Hard Disk Power Down Mode	Disabled	▶ Enabled
Standby Time Out (Minute)	Disabled	
Suspend Time Out (Minute)	Disabled	
Throttle Slow Clock Ratio	50%-56.25%	
Display Activity	Ignore	
IRQ3	Monitor	
IRQ4	Monitor	
IRQ5	Ignore	
IRQ7	Monitor	
IRQ9	Ignore	
IRQ10	Ignore	
IRQ11	Ignore	
IRQ13	Ignore	
IRQ14	Monitor	
IRQ15	Ignore	
		ESC:Exit ↑↓:Sel PgUp/PgDn:Modify F1:Help F2/F3:Color

**Power Management /APM**

Select Enabled to activate the chipset Power Management and APM (Advanced Power Management) features.

**Available Options:** Disabled, Enabled

**Default setting:** Enabled

**Video Power Down Mode**

This field specifies the power conserving state that video subsystem enters after the specified period of display inactivity has expired.

**Available Options:** Disabled, Standby, Suspend

**Default setting:** Disabled

**Hard Disk Power Down Mode**

This field specifies the power conserving state that the hard disk drive enters after the specified period of hard drive inactivity has expired.

**Available Options:** Disabled, Standby, Suspend

**Default setting:** Disabled

**Standby Time Out (Minute)**

This field specifies the length of a period of system inactivity (like hard disk or video) while in full power on state. When this length of time expires, the system enters Standby power state.

**Available Options:** Disabled, 1 Minute, 2 Minute, 4 Minute, and 8 Minute, up to 60 Minute.

**Default setting:** Disabled

**Suspend Time Out (Minute)**

This field specifies the length of a period of system inactivity (like hard disk or video) while in Standby state. When this length of time expires, the system enters Suspend power state.

**Available Options:** Disabled, 1 Minute, 2 Minute, 4 Minute, and 8 Minute, up to 60 Minute.

**Default setting:** Disabled

**Throttle Slow Clock Ratio**

When the system enter Suspend or standby mode, the CPU clock runs only part of the time. You may select the percent of time that the clock runs.

**Available Options:** 0%-6.25, 25%37.5%, 75%87.5% and 93.75%-100%

**Default setting:** 50%-56.25%

**IRQ3 ~IRQ15**

This field specifies the power down mode of the system based on the device. When the system does not receive signals from the device, it will enter the Power Down mode immediately. To enable the power saving mode, select Monitor. To disable it, select Ignore.

## PCI/PLUG AND PLAY

AMIBIOS SETUP - PCI / PLUG AND PLAY SETUP (C)2001 American Megatrends, Inc. All Rights Reserved		
Plug and Play Aware O/S	No	<b>Available Options:</b> ▶ 32 64 96 128 160 192 224 248 248  ESC:Exit ↑↓:Sel PgUp/PgDn:Modify F1:Help F2/F3:Color
Clear NURAM	No	
<b>PCI Latency Timer (PCI Clocks)</b>	<b>32</b>	
Primary Graphics Adapter	PCI	
PCI UGA Palette Snoop	Disabled	
Allocate IRQ to PCI UGA	No	
PCI IDE BusMaster	Disabled	
DMA Channel 0	PnP	
DMA Channel 1	PnP	
DMA Channel 3	PnP	
DMA Channel 5	PnP	
DMA Channel 6	PnP	
DMA Channel 7	PnP	
IRQ3	PCI/PnP	
IRQ4	PCI/PnP	
IRQ5	PCI/PnP	
IRQ7	PCI/PnP	
IRQ9	PCI/PnP	
IRQ10	PCI/PnP	
IRQ11	PCI/PnP	
IRQ14	PCI/PnP	
IRQ15	PCI/PnP	

**Plug and Plug Aware O/S**

Set to Yes to inform BIOS that the operating system can handle Plug and Play (PnP) devices.

**Available Options:** Yes, No

**Default setting:** No

**PCI Latency Timer**

This field specifies the latency timings (in PCI clock) PCI devices installed in the PCI expansion bus.

**Available Options:** 32, 64, 96, 128, 160, 192, 224, and 248

**Default setting:** 64

**Primary Graphics Adapter**

This field specifies which VGA display will be used when the system is boot. You can select either the onboard AGP or the VGA card installed on the PCI bus.

**Available Options:** AGP, PCI

**Default setting:** PCI

**❑ PCI VGA Palette Snoop**

When Enabled is selected, multiple VGA devices operating on different buses can handle data from the CPU on each set of palette registers on every video device. Bit 5 of the command register in the PCI device configuration space is the VGA Palette Snoop bit. (0 is disabled).

**Available Options:**

Disabled: Data read and written by the CPU is only directed to the PCI VGA devices palette registers.

Enabled: Data read and written by the CPU is directed to both the PCI VGA devices palette registers.

**Default setting:** Disable

**❑ Allocate IRQ to PCI AGP**

When a PCI or AGP VGA device is installed, you can assign an IRQ to this device. Selecting Yes, BIOS will auto-assign IRQ to the device. Selecting No, no IRQ will be assigned to the VGA device.

**Available Options:** Yes, No

**Default setting:** No

**❑ PCI IDE BusMaster**

This option is to specify that the IDE controller on the PCI local bus have bus-mastering capability.

**Available Options:** Enable, Disable

**Default setting:** Disable

**❑ DMA Channel 0 – 7**

When I/O resources are controlled manually, you can assign each system DMA as one of the following types, based on the type of device using the interrupt:

ISA/EISA devices comply with the original PC AT bus specification, requiring a specific interrupt (Such as IRQ5 for COM1).

PnP (PCI/ISA) devices: comply with the Plug and Play standard, whether designed for PCI or ISA bus architecture.

**Available Options:** PnP, ISA/EISA

**Default setting:** PnP

□ **IRQ 3-15**

When I/O resources are controlled manually, you can assign each system interrupt as one of the following types, based on the type of device using the interrupt:

ISA/EISA devices comply with the original PC AT bus specification, requiring a specific interrupt (Such as IRQ5 for COM1).

PnP (PCI/ISA) devices: comply with the Plug and Play standard, whether designed for PCI or ISA bus architecture.

## PERIPHERAL SETUP

This section describes the function of peripheral features.

AMIBIOS SETUP - PERIPHERAL SETUP (C)2001 American Megatrends, Inc. All Rights Reserved		
<b>OnBoard FDC</b>	<b>Auto</b>	Available Options: ▶ Auto Disabled Enabled  ESC:Exit ↑:Sel PgUp/PgDn:Modify F1:Help F2/F3:Color
OnBoard Serial Port1	Auto	
OnBoard Serial Port2	Auto	
OnBoard Parallel Port	Auto	
Parallel Port Mode	Normal	
EPP Version	N/A	
Parallel Port DMA Channel	N/A	
Parallel Port IRQ	Auto	
OnBoard IDE	Both	
IDE Connection Cable	40-Pin	
OnBoard AC'97 Audio	Enabled	
OnBoard Legacy Audio	Disabled	
Sound Blaster	Disabled	
SB I/O Base Address	220h-22Fh	
SB IRQ Select	5	
SB DMA Select	1	

**OnBoard FDC**

This field enables the floppy drive controller on the PC104-688VL.

**Available Options:** Disabled, Enabled and Auto

**Default setting:** Auto

**OnBoard Serial Port 1**

These fields select the I/O port address for each Serial port. Refer to Table 2-2.

**Available Options:** Auto, Disabled, 3F8H/COM1, 2F8H/COM2, and 3E8H/COM3, 2E8H/COM4.

**Default setting:** Auto

**OnBoard Serial Port 2**

These fields select the I/O port address for each Serial port. Refer to Table 2-2.

**Available Options:** Auto, Disabled, 3F8H/COM1, 2F8H/COM2, and 3E8H/COM3, 2E8H/COM4.

**Default setting:** Auto

**OnBoard Parallel Port**

This field selects the I/O port address for parallel port.

**Available Options:** Auto, Disabled, 378, 278, and 3BCH

**Default setting:** Auto

**EPP Version**

This field specifies the EPP version for the Parallel Port Mode specification used in the system and is not configurable. If Normal or ECP is selected, this field displays N/A, meaning not available.

**Available Options:** N/A, 1.7, 1.9

**Default setting:** N/A

**Parallel Port Mode**

This field specifies the parallel port mode. ECP and EPP are both bi-directional data transfer schemes that adhere to the IEEE P1284 specifications.

**Available Options:** N/A, Normal, Bi-Dir, EPP, and ECP

**Default setting:** Normal

**Parallel Port IRQ**

This field specifies the IRQ for the parallel port.

**Available Options:** Auto, N/A, 5, 7

**Default setting:** Auto

**Parallel Port DMA Channel**

This option is only available if the setting for the parallel Port Mode option is ECP.

**Available Options:** N/A, 0,1,3

**Default setting:** N/A

**On-Board IDE**

This field specifies the IDE channel that can be applied when using CN3 IDE hard disk connector.

**Available Options:** Disabled, Primary, and Secondary, Both

**Default setting:** Both

**IDE Connection Cable**

This field specifies the select IDE use 40-pin or 40pin-80 conductor cable that can be applied when using UltraDMA/66/100 devices on CN3 IDE hard disk connector.

**Available Options:** 40-pin, 80-pin

**Default setting:** 40-pin

**OnBoard AC'97 Audio**

This field specifies the internal Audio Control.

**Available Options:** Disable, Enable

**Default setting:** Enable

**Sound Blaster**

This field if you want to use the Sound Blaster emulation feature.

**Available Options:** Disable, Enable

**Default setting:** Disable

**SB I/O Base Address**

These fields select the I/O port address for Audio.

**Available Options:** 220H~22FH, 240H~24FH, 260H~26FH and 280~28FH

**Default setting:** 220H~22FH

**SB IRQ Select**

This field specifies the IRQ for the Audio.

**Available Options:** Disable, 5,7 and 10

**Default setting:** 5

**SB DMA Select**

This field specifies the DMA for internal Audio Control.

**Available Options:** Disable, 0, 1,2 and 3

**Default setting:** 1

## Hardware Monitor Setup

On the Hardware Monitor Setup screen, you can set up or monitor the system temperature, CPU voltage, and VIA C3 CPU Ration and CPU fan speed...

AMIBIOS SETUP - HARDWARE MONITOR SETUP (C)2001 American Megatrends, Inc. All Rights Reserved	
--≡ System Hardware Monitor ≡--	
Current System Temperature	
Fan1 Speed	0 RPM
CPU VCORE	+1.125V
CPU VTT	+1.500V
+ 3.300V	+3.359V
ESC:Exit ↑:Sel PgUp/PgDn:Modify F1:Help F2/F3:Color	

### □ System Hardware Monitor

In this field, you can monitor or detect the followings items. These items are view-only and cannot be changed.

- Current System Temperature
- Fan1 Speed
- CPU1 VCORE
- CPU VTT
- +3.300V

## Password Setup

There are two security passwords: Supervisor and User. Supervisor is a privileged person that can change the User password from the BIOS.

According to the default setting, both access passwords are not set up and are only valid after you set the password from the BIOS.

To set the password, please complete the following steps.

1. Select **Change Supervisor Password**.
2. Type the desired password (up to 8 character length) when you see the message, "Enter New Supervisor Password."
3. Then you can go on to set a user password (up to 8 character length) if required. Note that you cannot configure the User password until the Supervisor password is set up.
4. Enter Advanced CMOS Setup screen and point to the Password Checkup field.
5. Select Always or Setup.
  - ✧ **Always:** a visitor who attempts to enter BIOS or operating system will be prompted for password.
  - ✧ **Setup:** a visitor who attempts to the operating system will be prompted for user password. You can enter either User password or Supervisor password.
6. Point to **Save Settings and Exit** and press Enter.
7. Press Y when you see the message, "Save Current Settings and Exit (Y/N)?"

Note: it is suggested that you write down the password in a safe place to avoid that password may be forgotten or missing.

To set the password, please complete the following steps.

1. Select **Change Supervisor Password**.
2. Press Enter instead of entering any character when you see the message, "Enter New Supervisor Password."
3. Thus you can disable the password.



## Chapter 5 Driver and Utility

The enclosed diskette includes PC104-688VL VGA driver and LAN driver.

### VGA /Audio Driver for WIN98/WIN95

Step 1: To install the VGA driver, insert the CD ROM into the CD ROM device, and enter  
DRIVER>VGA>Via8601T>Win98\_Me.

Step 2: Open the Control Panel and double-click "SYSTEM" icon and then Click the  
"DEVICE Manager" Tab and double click "VGA Display".

Step 3: Click on DRIVE from the menu bar and new screen appears with the "Update  
Driver" button and then system will search VGA drive file starting form A: drive.

Step 4: As the installation is completed, the system will generate the message as follows.

Yes, I want to restart my computer now. Installation is done!

No, I will restart my computer later.

System must be restart then complete the installation.

Step 5: In the WINDOWS98/ME, you can find the <DISPLAYL> icon located in the  
{CONTROL PANEL} group.

Step 6: Adjust the <Refresh Rate>, <Font size> and <Resolution>.

**Note:** In the VGA/Audio/SysChip >Via8601/VT686B>NT4.0, WINXP\_2K directory, a Install.txt  
file is included to provide installation information

## **BIOS Flash Utility**

In the <UTILITY> directory, there is the FLASH835.EXE file.

Step 1: Use the AMIFLASH.COM program to update the BIOS setting.

Step 2: And then refer to the chapter "BIOS Setup", as the steps to modify BIOS.

Step 3: Now the CPU board's BIOS loaded with is the newest program; user can use it to modify BIOS function in the future, when the BIOS add some functions.

## **LAN Utility**

Step 1: To install the LAN utility OR driver, insert the CD ROM into the CD ROM device, and enter DRIVER>LAN>RTL8139C>DIAG. If your system is not equipped with a CD ROM device, copy the LAN VGA driver from the CD ROM to a 1.44" diskette.

Step 2 Execute install.exe file.

**Note:** In the LAN directory, a HELPME.EXE file is included to provide installation information

## Watchdog Timer

This section describes how to use the Watchdog Timer, including disabled, enabled, and trigger functions.

The PC104-688VL is equipped with a programmable time-out period watchdog timer. You can use your own program to enable the watchdog timer. Once you have enabled the watchdog timer, the program should trigger the I/O every time before the timer times out. If your program fails to trigger or disable this timer before it times out, e.g. because of a system hang-up, it will generate a reset signal to reset the system. The time-out period can be programmed to be set from 1 to 256 seconds or 1 to 256 minutes.

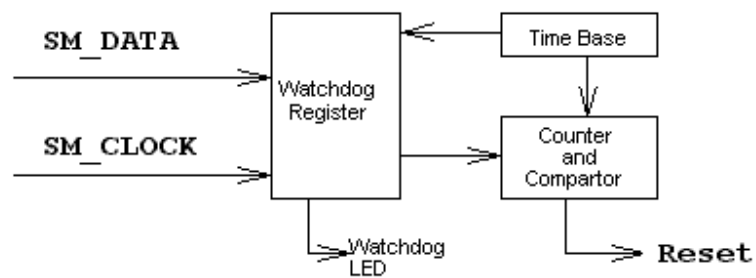

### Watchdog Timer Setting

The watchdog timer is a circuit that may be used from your program software to detect system crashes or hang-ups. LED1 on this CPU board is the watchdog timer indicator, which is located at the upper-left corner above the USB connector. Whenever the watchdog timer is enabled, the LED will blink to indicate that the timer is counting. The watchdog timer is automatically disabled after reset.

Once you have enabled the watchdog timer, your program must trigger the watchdog timer every time before it times out. After you trigger the watchdog timer, it will be set to non-zero value to watchdog counter and start to count down again. If your program fails to trigger the watchdog timer before time-out, it will generate a reset pulse to reset the system.

The factor of the watchdog timer time-out constant is approximately 1 second. The period for the watchdog timer time-out period is between 1 to 256 timer factors. If you want to reset your system when watchdog times out, the following table listed the relation of timer factors between time-out periods.

Reset Time Factor	Time-Out Period Sec/Minutes
01h	1
02h	2
03h	3
04h	4
05h	5
06h	6
~	~
FFh	256

- Watchdog Timer Enabled**
- Watchdog Timer Trigger**
- Watchdog Timer Disabled**

**Note:** In the DRIVER/WatchDog/F75101r directory a demo file is included to provide watchdog control information and assemble source code.

## Chapter 6 Technical Reference

This section outlines the errors that may occur when you operate the system, and also gives you the suggestions on solving the problems.

Topic include:

- Trouble Shooting for Error Messages
- Technical Reference

### Trouble Shooting for Error Messages

The following information informs the error messages and troubleshooting. Please adjust your systems according to the messages below. Make sure all the components and connectors are in proper position and firmly attached. If the errors still exist, please contact with your distributor for maintenance.

#### ❑ **POST BEEP**

Currently there are two kinds of beep codes in BIOS setup.

- One indicates that a video error has occurred and the BIOS cannot initialize the video screen to display any additional information. This beep code consists of a single long beep followed by three short beeps.
- The other indicates that an error has occurred in your DRAM. This beep code consists of a constant single long beep.

#### ❑ **CMOS BATTERY FAILURE**

When the CMOS battery is out of work or has run out, the user has to replace it with a new battery.

❑ **CMOS CHECKSUM ERROR**

This error informs that the CMOS has corrupted. When the battery runs weak, this situation might happen. Please check the battery and change a new one when necessary.

❑ **DISPLAY SWITCH IS SET INCORRECTLY**

Display switch on the motherboard can be set to either monochrome or color. This indicates the switch is set to a different setting than indicated in BIOS Setup. Determine which setting is correct, and then either turn off the system and change the jumper, or enter BIOS Setup and change the video selection.

❑ **DISK BOOT FAILURE**

When you can't find the boot device, insert a system disk into Drive A and press < Enter >. Make sure both the controller and cables are all in proper positions, and also make sure the disk is formatted. Then reboot the system.

❑ **DISKETTE DRIVES OR TYPES MISMATCH ERROR**

When the diskette drive type is different from CMOS, please run setup or configure the drive again.

❑ **ERROR ENCOUNTERED INITIALIZING HARD DRIVE**

When you can't initialize the hard drive, ensure the following things:

1. The adapter is installed correctly
2. All cables are correctly and firmly attached
3. The correct hard drive type is selected in BIOS Setup

❑ **ERROR INITIALIZING HARD DISK CONTROLLER**

When this error occurs, ensure the following things:

1. The cord is exactly installed in the bus.
2. The correct hard drive type is selected in BIOS Setup
3. Whether all of the jumpers are set correctly in the hard drive

❑ **FLOPPY DISK CONTROLLER ERROR OR NO CONTROLLER PRESENT**

When you cannot find or initialize the floppy drive controller, please ensure the controller is in proper BIOS Setup. If there is no floppy drive installed, ensure the Diskette Drive selection in Setup is set to NONE.

❑ **KEYBOARD ERROR OR NO KEYBOARD PRESENT**

When this situation happens, please check keyboard attachment and no keys being pressed during the boot. If you are purposely configuring the system without a keyboard, set the error halt condition in BIOS Setup to HALT ON ALL, BUT KEYBOARD. This will cause the BIOS to ignore the missing keyboard and continue the boot procedure.

❑ **MEMORY ADDRESS ERROR**

When the memory address indicates error. You can use this location along with the memory map for your system to find and replace the bad memory chips.

❑ **MEMORY SIZE HAS CHANGED**

Memory has been added or removed since last boot. In EISA mode, use Configuration Utility to re-configure the memory configuration. In ISA mode enter BIOS Setup and enter the new memory size in the memory fields.

❑ **MEMORY VERIFYING ERROR**

It indicates an error verifying a value is already written to memory. Use the location along with your system's memory map to locate the bad chip.

❑ **OFFENDING ADDRESS MISSING**

This message is used in connection with the I/O CHANNEL CHECK and RAM PARITY ERROR messages when the segment that has caused the problem cannot be isolated.

❑ **REBOOT ERROR**

When this error occurs that requires you to reboot. Press any key and the system will reboot.

❑ **SYSTEM HALTED**

Indicates the present boot attempt has been aborted and the system must be rebooted. Press and hold down the CTRL and ALT keys and press DEL.

## Technical Reference

### Real-Time Clock and Non-Volatile RAM

The PC104-688VL contains a real-time clock compartment that maintains the date and time in addition to storing configuration information about the computer system. It contains 14 bytes of clock and control registers and 114 bytes of general purpose RAM. Because of the use of CMOS technology, it consumes very little power and can be maintained for long periods of time using an internal Lithium battery. The contents of each byte in the CMOS RAM are listed below:

Address	Description
00	Seconds
01	Second alarm
02	Minutes
03	Minute alarm
04	Hours
05	Hour alarm
06	Day of week
07	Date of month
08	Month
09	Year
0A	Status register A
0B	Status register B
0C	Status register C
0D	Status register D
0E	Diagnostic status byte
0F	Shutdown status byte
10	Diskette drive type byte, drive A and B
11	Fixed disk type byte, drive C
12	Fixed disk type byte, drive D
13	Reserved
14	Equipment byte
15	Low base memory byte
16	High base memory byte

Address	Description
17	Low expansion memory byte
18	High expansion memory byte
19-2D	Reserved
2E-2F	2-byte CMOS checksum
30	Low actual expansion memory byte
31	High actual expansion memory byte
32	Date century byte
33	Information flags (set during power on)
34-7F	Reserved for system BIOS

**CMOS RAM Map**

Register	Description
00h -10h	Standard AT-compatible RTC and Status and Status Register data definitions
11h – 13h	Varies
14h	Equipment Bits 7-6 Number of Floppy Drives 00 1 Drive 01 2 Drives Bits 5-4 Monitor Type 00 Not CGA or MDA 01 40x25 CGA 01 2 Drives 80x25 CGA Bits 3 Display Enabled 0 Disabled 1 Enabled Bit 2 Keyboard Enabled 00 Not CGA or MDA 01 40x25 CGA 01 2 Drives 80x25 CGA Bit 1 Math Coprocessor Installed 0 Absent 1 Present Bit 0 Floppy Drive Installed 0 Disabled 1 Enabled
15h	Base Memory (in 1KB increments), Low Byte
16h	Base Memory (in 1KB increments), High Byte
17h	IBM-compatible memory (in 1KB increments), Low Byte
18h	IBM-compatible memory (in 1KB increments), High Byte (max 15 MB)
19h-2Dh	Varies
2Eh	Standard CMOS RAM checksum, high byte
2Fh	Standard CMOS RAM checksum, low byte
30h	IBM-compatible Extended Memory, Low Byte (POST) in KB
31h	IBM-compatible Extended Memory, High Byte (POST) in KB
32h	Century Byte
33h	Reserved. Do not use
34h	Reserved. Do not use
35h	Low byte of extended memory (POST) in 64 KB
36h	High byte of extended memory (POST) in 64 KB
37h-3Dh	Varies
3Eh	Extended CMOS Checksum, Low Byte (including 34h-3Dh)
3Fh	Extended CMOS Checksum, High Byte (including 34h-3Dh)

### I/O Port Address Map

Each peripheral device in the system is assigned a set of I/O port addresses, which also becomes the identity of the device. There is a total of 1K-port address space available. The following table lists the I/O port addresses used on the Industrial CPU Card.

Address	Device Description
000h - 01Fh	DMA Controller #1
020h - 03Fh	Interrupt Controller #1
040h - 05Fh	Timer
060h - 06Fh	Keyboard Controller
070h - 07Fh	Real Time Clock, NMI
080h - 09Fh	DMA Page Register
0A0h - 0BFh	Interrupt Controller #2
0C0h - 0DFh	DMA Controller #2
0F0h - 0FFh	Math Coprocessor
1F0h - 1F7h	IDE Interface
278h - 27Fh	Parallel Port #2(LPT2)
2F8h - 2FFh	Serial Port #2(COM2)
378h - 3FFh	Parallel Port #1(LPT1)
3B0h - 3BFh	Monochrome & Printer adapter
3C0h - 3CFh	EGA adapter
3D0h - 3DFh	CGA adapter
3F0h - 3F7h	Floppy Disk Controller
3F8h - 3FFh	Serial Port #1(COM1)
400h - 40Fh	Plug & Play ISA Bus
4D5h - 4D1h	Plug & Play ISA Bus
800h - 87Fh	Plug & Play ISA Bus
880h - 88Fh	Plug & Play ISA Bus
C00h - CFFh	Plug & Play ISA Bus
CF8h - CFFh	Plug & Play ISA Bus
E800h - E8FEh	Ethernet Controller
EC00h - EC1Eh	USB Controller
FC00h - FC0Eh	IDE Controller

**Interrupt Request Lines (IRQ)**

There are a total of 15 IRQ lines available on the Industrial CPU Card. Peripheral devices use interrupt request lines to notify CPU for the service required. The following table shows the IRQ used by the devices on the Industrial CPU Card.

Level	Function
IRQ0	System Timer Output
IRQ1	Keyboard
IRQ2	Interrupt Cascade
IRQ3	Serial Port #2
IRQ4	Serial Port #1
IRQ5	Reserved
IRQ6	Floppy Disk Controller
IRQ7	Parallel Port #1
IRQ8	Real Time Clock
IRQ9	Reserved
IRQ10	USB
IRQ11	Ethernet
IRQ12	PS2 Mouse
IRQ13	Math coprocessor
IRQ14	Primary IDE
IRQ15	Secondary IDE

### DMA Channel Map

The equivalent of two 8237A DMA controllers are implemented in the PC104-688VL board. Each controller is a four-channel DMA device that will generate the memory addresses and control signals necessary to transfer information directly between a peripheral device and memory. This allows high speed information transfer with less CPU intervention. The two DMA controllers are internally cascaded to provide four DMA channels for transfers to 8-bit peripherals (DMA1) and three channels for transfers to 16-bit peripherals (DMA2). DMA2 channel 0 provides the cascade interconnection between the two DMA devices, thereby maintaining IBM PC/AT compatibility.

The following is the system information of DMA channels:

<b>DMA Controller 1</b>	<b>DMA Controller 2</b>
Channel 0: Spare	Channel 4: Cascade for controller 1
Channel 1: Reserved for IBM SDLC	Channel 5: Spare
Channel 2: Diskette adapter	Channel 6: Spare
Channel 3: Spare	Channel 7: Spare

## Serial Ports

The ACEs (Asynchronous Communication Elements ACE1 to ACE2) are used to convert parallel data to a serial format on the transmit side and convert serial data to parallel on the receiver side. The serial format, in order of transmission and reception, is a start bit, followed by five to eight data bits, a parity bit (if programmed) and one, one and half (five-bit format only) or two stop bits. The ACEs are capable of handling divisors of 1 to 65535, and produce a 16x clock for driving the internal transmitter logic.

Provisions are also included to use this 16x clock to drive the receiver logic. Also included in the ACE is a completed MODEM control capability, and a processor interrupt system that may be software tailored to the computing time required to handle the communications link.

The following table is a summary of each ACE accessible register

DLAB	Port Address	Register
0	Base + 0	Receiver buffer (read)
		Transmitter holding register (write)
0	Base + 1	Interrupt enable
X	Base + 2	Interrupt identification (read only)
X	Base + 3	Line control
X	Base + 4	MODEM control
X	Base + 5	Line status
X	Base + 6	MODEM status
X	Base + 7	Scratched register
1	Base + 0	Divisor latch (least significant byte)
1	Base + 1	Divisor latch (most significant byte)

### ❑ Receiver Buffer Register (RBR)

Bit 0-7: Received data byte (Read Only)

### ❑ Transmitter Holding Register (THR)

Bit 0-7: Transmitter holding data byte (Write Only)

### ❑ Interrupt Enable Register (IER)

Bit 0: Enable Received Data Available Interrupt (ERBFI)

Bit 1: Enable Transmitter Holding Empty Interrupt (ETBEI)

Bit 2: Enable Receiver Line Status Interrupt (ELSI)

Bit 3: Enable MODEM Status Interrupt (EDSSI)

Bit 4: Must be 0

Bit 5: Must be 0

Bit 6: Must be 0

Bit 7: Must be 0

□ **Interrupt Identification Register (IIR)**

Bit 0: "0" if Interrupt Pending

Bit 1: Interrupt ID Bit 0

Bit 2: Interrupt ID Bit 1

Bit 3: Must be 0

Bit 4: Must be 0

Bit 5: Must be 0

Bit 6: Must be 0

Bit 7: Must be 0

□ **Line Control Register (LCR)**

Bit 0: Word Length Select Bit 0 (WLS0)

Bit 1: Word Length Select Bit 1 (WLS1)

WLS1	WLS0	Word Length
0	0	5 Bits
0	1	6 Bits
1	0	7 Bits
1	1	8 Bits

Bit 2: Number of Stop Bit (STB)

Bit 3: Parity Enable (PEN)

Bit 4: Even Parity Select (EPS)

Bit 5: Stick Parity

Bit 6: Set Break

Bit 7: Divisor Latch Access Bit (DLAB)

□ **MODEM Control Register (MCR)**

Bit 0: Data Terminal Ready (DTR)

Bit 1: Request to Send (RTS)

Bit 2: Out 1 (OUT 1)

Bit 3: Out 2 (OUT 2)

Bit 4: Loop

Bit 5: Must be 0

Bit 6: Must be 0

Bit 7: Must be 0

□ **Line Status Register (LSR)**

Bit 0: Data Ready (DR)

Bit 1: Overrun Error (OR)

Bit 2: Parity Error (PE)

Bit 3: Framing Error (FE)

Bit 4: Break Interrupt (BI)

Bit 5: Transmitter Holding Register Empty (THRE)

Bit 6: Transmitter Shift Register Empty (TSRE)

Bit 7: Must be 0

□ **MODEM Status Register (MSR)**

Bit 0: Delta Clear to Send (DCTS)

Bit 1: Delta Data Set Ready (DDSR)

Bit 2: Training Edge Ring Indicator (TERI)

Bit 3: Delta Receive Line Signal Detect (DSLSD)

Bit 4: Clear to Send (CTS)

Bit 5: Data Set Ready (DSR)

Bit 6: Ring Indicator (RI)

Bit 7: Received Line Signal Detect (RSLD)

**Divisor Latch (LS, MS)**

	LS	MS
Bit 0:	Bit 0	Bit 8
Bit 1:	Bit 1	Bit 9
Bit 2:	Bit 2	Bit 10
Bit 3:	Bit 3	Bit 11
Bit 4:	Bit 4	Bit 12
Bit 5:	Bit 5	Bit 13
Bit 6:	Bit 6	Bit 14
Bit 7:	Bit 7	Bit 15

Desired Baud Rate	Divisor Used to Generate 16x Clock
300	384
600	192
1200	96
1800	64
2400	48
3600	32
4800	24
9600	12
14400	8
19200	6
28800	4
38400	3
57600	2
115200	1

**Parallel Ports**

□ **Register Address**

Port Address	Read/Write	Register
Base + 0	Write	Output data
Base + 0	Read	Input data
Base + 1	Read	Printer status buffer
Base + 2	Write	Printer control latch

□ **Printer Interface Logic**

The parallel portion of the SMC37C669 makes the attachment of various devices that accept eight bits of parallel data at standard TTL level.

□ **Data Swapper**

The system microprocessor can read the contents of the printer's Data Latch through the Data Swapper by reading the Data Swapper address

□ **Printer Status Buffer**

The system microprocessor can read the printer status by reading the address of the Printer Status Buffer. The bit definitions are described below:

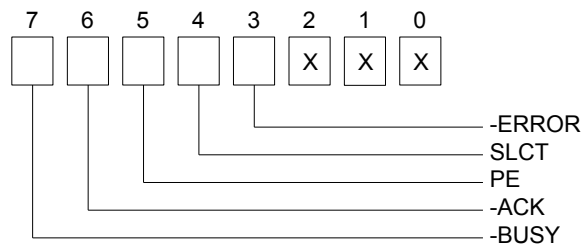

NOTE: X represents not used.

Bit 7: This signal may become active during data entry, when the printer is off-line during printing, or when the print head is changing position or in an error state. When Bit 7 is active, the printer is busy and cannot accept data.

Bit 6: This bit represents the current state of the printer's ACK signal. A 0 means the printer has received the character and is ready to accept another. Normally, this signal will be active for approximately 5 microseconds before receiving a BUSY message stops.

Bit 5: A 1 means the printer has detected the end of the paper.

Bit 4: A 1 means the printer is selected.

Bit 3: A 0 means the printer has encountered an error condition.

□ **Printer Control Latch & Printer Control Swapper**

The system microprocessor can read the contents of the printer control latch by reading the address of printer control swapper. Bit definitions are as follows:

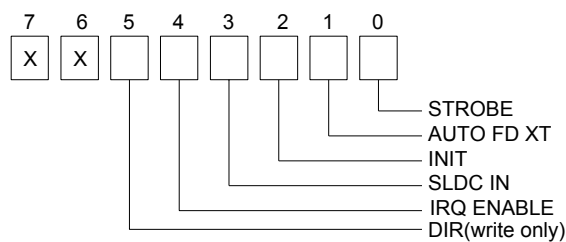

NOTE: X represents not used.

- Bit 5: Direction control bit. When logic 1, the output buffers in the parallel port are disabled allowing data driven from external sources to be read; when logic 0, they work as a printer port. This bit is write-only.
- Bit 4: A 1 in this position allows an interrupt to occur when ACK changes from low state to high state.
- Bit 3: A 1 in this bit position selects the printer.
- Bit 2: A 0 starts the printer (50 microseconds pulse, minimum).
- Bit 1: A 1 causes the printer to line-feed after a line is printed.
- Bit 0: A 0.5 microsecond minimum highly active pulse clocks data into the printer. Valid data must be present for a minimum of 0.5 microseconds before and after the strobe pulse.

**Dimension**

**PC104-688VL**

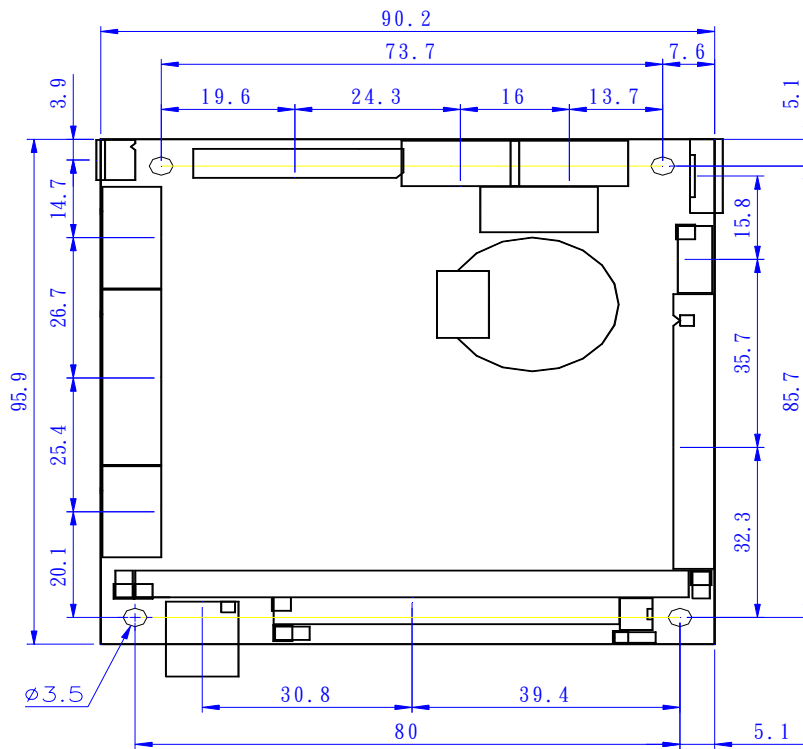

Unit: mm

**FB4605**

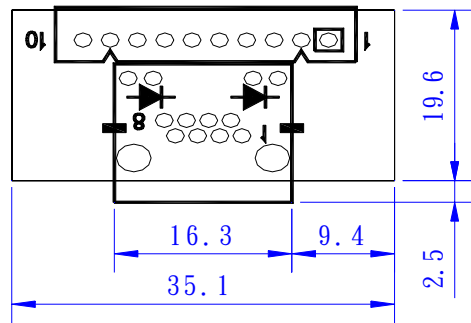

**FB4641**

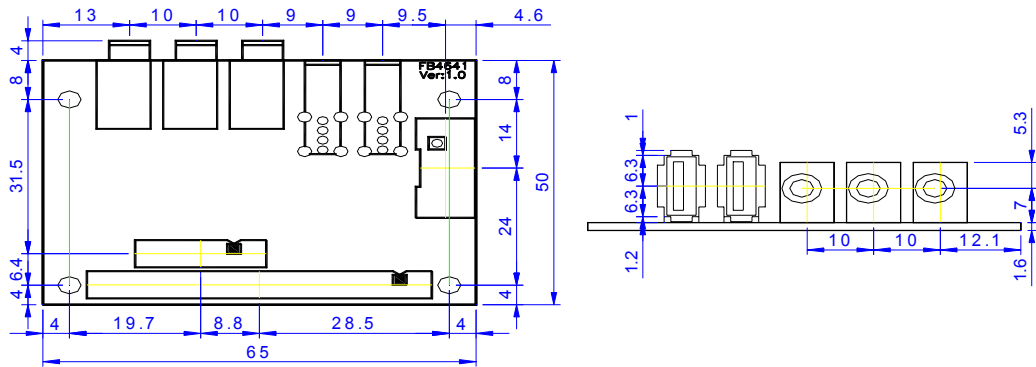

Unit: mm